

SURVEY PLAT FOR: UNITED EDGE

PART OF THE EAST 1/2
OF THE SOUTHEAST 1/4
OF SECTION 6, T5N - R5E,
ADAMS TOWNSHIP,
DEFIANCE COUNTY, OHIO

Bockrath & Associates
Engineering and Surveying, LLC
 115 S. Fair Avenue, Suite A - Ottawa - Ohio
 Phone: 419.523.5789

THIS SURVEY WAS PERFORMED WITHOUT THE
BENEFIT OF A TITLE EXAMINATION. BEYOND
THE DEED DOCUMENTS CITED ON THE SURVEY
DRAWING THERE MAY BE RECORDED OR UN-
RECORDED EASEMENTS AND/OR
ENCUMBRANCES BENEFITING OR ENCUMBERING
THE SURVEYED PROPERTY WHICH ARE NOT
SHOWN ON THIS DRAWING.

I HEREBY CERTIFY THIS TO BE A SURVEY MADE UNDER MY SUPERVISION
AND THAT THE MONUMENTS ARE FOUND AND/OR SET AS INDICATED.

5-22-23
Date

Seth D. Schroeder
Seth D. Schroeder, P.S.
Registered Surveyor No. 8784
115 S. Fair Avenue, Suite A
Ottawa, Ohio 45875
419-523-5789

NE CORNER,
SE 1/4,
SECTION 6

**NOTE: SURVEY BEARINGS BASED ON OHIO NORTH
ZONE STATE PLANE COORDINATES OBTAINED FROM
THE OHIO DOT VRS NETWORK**

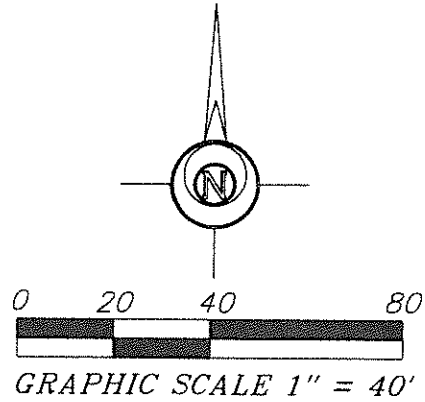

LEGEND

- 5/8 INCH REBAR WITH ID CAP SET
- MB MONUMENT BOX FOUND
- MAG MAG NAIL FOUND
- MAGS MAG NAIL SET
- POB POINT OF BEGINNING
- POC POINT OF COMMENCEMENT

SANDRA K. WONDERS, TRUSTEE
 IRREVOCABLE TRUST OF MILDRED M. ARNOS
 OR VOL 408 - PG 1215
 120 ACRES (PER TAX RECORD)
 PN. A07-0006-0-001-00

NOTE
PARCEL IS INTENDED TO SERVE
AS PARKING LOT FOR CHURCH
LOCATED DIRECTLY SOUTH OF
NEW SPLIT

