

*NOTE: 14.5' ALLEY SHOWN ON SOUTH DEFIANCE ADDITION (PB 1 - PG 15)

&
ON THE MAP OF THE FIRST WARD OF DEFIANCE, ALSO KNOWN AS THE AUDITOR'S PLAT OF LOTS BETWEEN THE MAUMEE AND AUGLAIZE RIVERS (PB 1 - PG 23)

**NOTE: UNABLE TO FIND ANY VACATION INFO. FOR 14.5' ALLEY

PLAT REFERENCES:
MAP OF THE FIRST WARD OF DEFIANCE, ALSO KNOWN AS THE AUDITOR'S PLAT OF LOTS BETWEEN THE MAUMEE AND AUGLAIZE RIVERS (PB 1 - PG 23)
SOUTH DEFIANCE ADDITION (PB 1 - PG 15)
HEIDEPRIEM ADDITION (PB 1 - PG 33)
KROTZ'S ADDITION (PB 1 - PG 17)

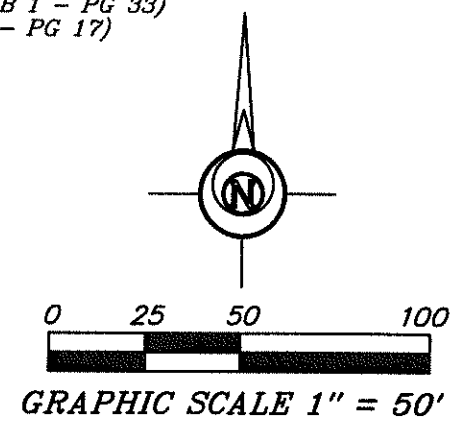

LEGEND

- ⊙ 5/8 INCH REBAR WITH ID CAP FOUND
- ⊙ 5/8 INCH REBAR FOUND
- 1/2 INCH REBAR FOUND
- ⊠ SQUARE BOLT FOUND
- P-FD 1/2 INCH IRON PIPE FOUND
- 1"-FD 1 INCH IRON PIN FOUND IN CONCRETE
- POB POINT OF BEGINNING
- R RECORDED
- M MEASURED

NOTE: SURVEY BEARINGS BASED ON OHIO NORTH ZONE STATE PLANE COORDINATES OBTAINED FROM THE OHIO DOT VRS NETWORK

I HEREBY CERTIFY THIS TO BE A SURVEY MADE UNDER MY SUPERVISION AND THAT THE MONUMENTS ARE FOUND AND/OR SET AS INDICATED.

11-15-17
Date

Gregory A. Bockrath
Gregory A. Bockrath, P.S.
Registered Surveyor No. 8306.
115 S. Fair Avenue, Suite A
Ottawa, Ohio 45875
419-523-5789



SURVEY PLAT FOR: HUNTINGTON NATIONAL BANK	
BEING LOT 262 IN SOUTH DEFIANCE ADDITION, LOT 8 IN HEIDEPRIEM ADDITION & PART OF LOT 107 IN THE AUDITOR'S PLAT OF LOTS BETWEEN THE MAUMEE AND AUGLAIZE RIVERS, T4N - R4E, CITY OF DEFIANCE, DEFIANCE COUNTY, OHIO	
BOCKRATH & ASSOCIATES ENGINEERING and SURVEYING, LLC 115 S. FAIR AVENUE SUITE A - OTTAWA, OH 45875 PHONE: 419-523-5789 - FAX: 419-523-5799	1 1

THIS SURVEY WAS PERFORMED WITHOUT THE BENEFIT OF A TITLE EXAMINATION. BEYOND THE DEED DOCUMENTS CITED ON THE SURVEY DRAWING THERE MAY BE RECORDED OR UN-RECORDED EASEMENTS AND/OR ENCUMBRANCES BENEFITING OR ENCUMBERING THE SURVEYED PROPERTY WHICH ARE NOT SHOWN ON THIS DRAWING.