

POC P1 & P2 M NW CORNER, NW 1/4, SECTION 30

S 01°40'25" W 585.55'

S 88°25'35" E 199.00'

NOTE: THE WEST LINE OF THE NE1/4 OF SECTION 30 IS 1.00' EAST AND PARALLEL TO THE EAST R/W LINE OF GREENHOUSE AVE. THIS 1.00' WIDE STRIP IS PART OF LOT 69 OF THE SAUNDERS-SNYDER ADDITION.

NAPOLEON WASH-N-FILL, INC.
DEED VOL 233 - PG 687
0.657 ACRES (RECORDED)
PN. J11-0030-0-010-01

WILLIAM K. DEGLER JR., ETAL
OR VOL 329 - PG 959
3.103 ACRES (RECORDED)
PN. J09-0030-0-010-00

GREENHOUSE AVE.

EAST R/W LINE OF GREENHOUSE AVE.

(ASSUMED BEARING) N 01°40'25" E 143.04'

WEST LINE, NW 1/4, SEC. 30 (SEE NOTE) 143.00'

S 88°25'35" E 200.00'

PARCEL 1
0.660 AC.

0.003 AC. IN NW1/4 (PT. LOT 69 IN THE SAUNDERS-SNYDER ADDITION)
0.657 AC. IN NE1/4

N 88°03'15" W 200.00'

PT. LOT 69 SAUNDERS-SNYDER ADDITION)

0.15' N, 0.30' E.

POB P2

S 01°40'25" W 143.00'

N 01°40'25" E 287.34'

S 01°40'25" W 144.34'

GRAHAM-HANCOCK-LOVE, AMVET POST 1991
OR VOL 71 - PG 458
2.745 ACRES (RECORDED)
PN. J04-0030-0-010-05

PARCEL 2
2.085 AC.

S 88°25'35" E 315.00'

N 88°03'15" W 315.00'

0.50' N, 1.30' E.

212.36'

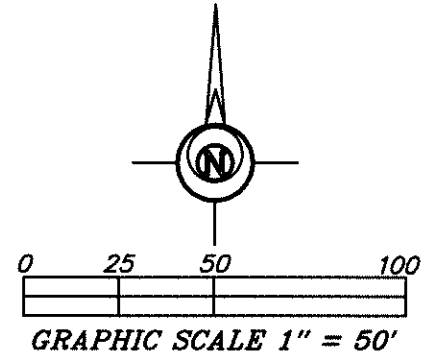

LEGEND

- 5/8 INCH REBAR WITH ID CAP SET
5/8 INCH REBAR WITH ID CAP FOUND
5/8 INCH REBAR FOUND
MONUMENT BOX FOUND
MAG MAG NAIL SET
POB POINT OF BEGINNING
POC POINT OF COMMENCEMENT

SPRUCE STREET SELF STORAGE, LLC
OR VOL 386 - PG 647
1.412 ACRES (RECORDED)
PN. J09-0030-0-010-07

290.76'

211.97'

SPRUCE STREET (60' R/W)

NOTE: SURVEY BEARINGS BASED ON OHIO NORTH ZONE STATE PLANE COORDINATES OBTAINED FROM THE OHIO DOT VRS NETWORK

THIS SURVEY WAS PERFORMED WITHOUT THE BENEFIT OF A TITLE EXAMINATION. BEYOND THE DEED DOCUMENTS CITED ON THE SURVEY DRAWING THERE MAY BE RECORDED OR UNRECORDED EASEMENTS AND/OR ENCUMBRANCES BENEFITING OR ENCUMBERING THE SURVEYED PROPERTY WHICH ARE NOT SHOWN ON THIS DRAWING.

I HEREBY CERTIFY THIS TO BE A SURVEY MADE UNDER MY SUPERVISION AND THAT THE MONUMENTS ARE FOUND AND/OR SET AS INDICATED.

11-10-2021 Date

Seth D. Schroeder, P.S. Registered Surveyor No. 8784 115 S. Fair Avenue, Suite A Ottawa, Ohio 45875 419-523-5789



FILENAME: 21-377-BDL-10-14-21.scj DATE: 10/14/21 SURVEY PLAT FOR: GRAHAM - HANCOCK - LOVE AMVET POST 1991

PART OF THE NW1/4 OF THE NE1/4 & PART OF LOT 69 IN THE SAUNDERS-SNYDER ADDITION, OF SECTION 30, T4N - R5E, CITY OF DEFIANCE, DEFIANCE COUNTY, OHIO

BOCKRATH & ASSOCIATES ENGINEERING and SURVEYING, LLC 115 S. FAIR AVENUE, SUITE A - OTTAWA, OH 45875 PHONE: 419-523-5789 - FAX: 419-523-5799

1/1