

Plat of Survey

Being Lots 19, 20, 21, 22 and part of Lot 23, Warner and Harts Addition,
Also, part of Lots 14 and 136 and all of Lot 357, Auditor's Plat of Lots,
Village of Hicksville, Defiance County, Ohio.

For: Robert L. Stotler Jr.
Deed Ref: Vol. 218, Pg. 143
Vol. 231, Pg. 458
OR 385, Pg. 2668

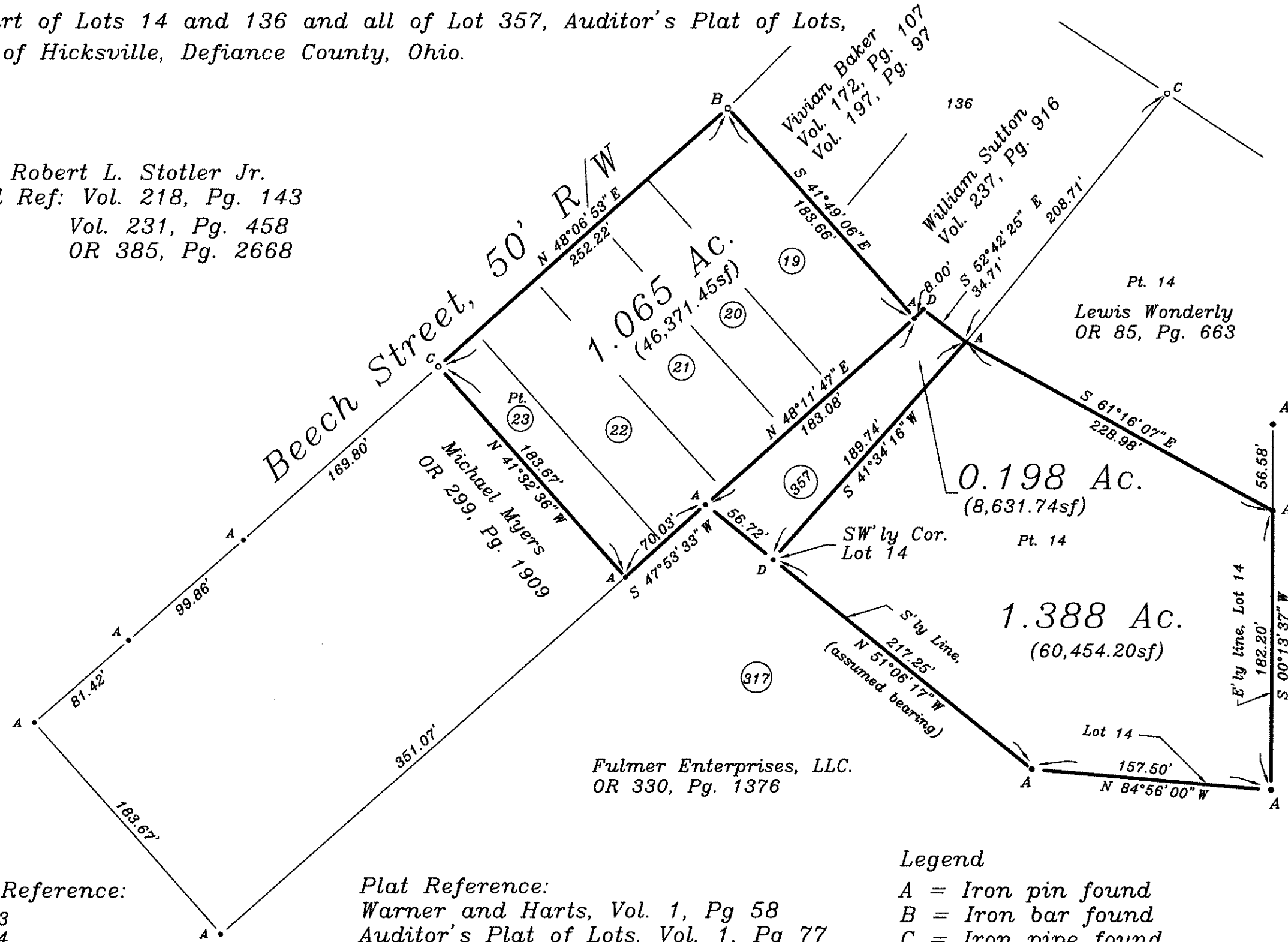

Survey Reference:

- H-46-003
- H-46-004
- H-01-080
- H-01-191
- H-01-222

Plat Reference:

Warner and Harts, Vol. 1, Pg 58
Auditor's Plat of Lots, Vol. 1, Pg 77

Legend

- A = Iron pin found
- B = Iron bar found
- C = Iron pipe found
- D = Iron pin & cap set

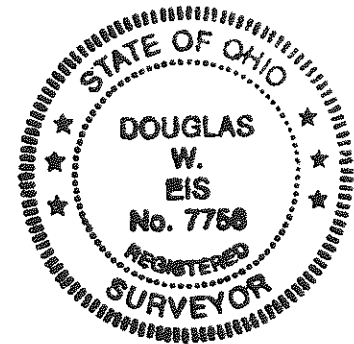
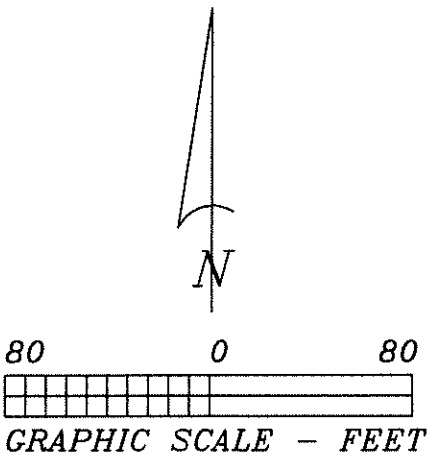

I hereby certify this survey and notes to be correct to the best of my knowledge.

Douglas W. Eis

Douglas W. Eis
Registered Surveyor No. 7758
D.W. Eis Surveying
16-883 St. Rt. 281
Holgate, Ohio 43527
(419) 762-5468
November 3, 2016
Survey No. B2436-D-VHic-1-16-17