

**5.193 ACRES**  
PT. PN. H210002000401

**NE 1/4, NW 1/4**  
SHEA M. & STEPHANIE S. WALKUP  
OR VOL 367 - PG 189  
PARCEL NO. H210002000401  
72.336 ACRES (RECORDED)  
SURVEY VOL. 11-2-10

ROGER D. BARTLETT, JR.  
OR VOL 257 - PG 2744  
2.29 ACRES | PN. H210002000404

MICHAEL A. & WENDY MCKEEVER  
OR VOL 419 - PG 2227  
2.00 ACRES | PN. H210002000400  
SURVEY VOL. 11-2-9

DONALD L. & DOROTHY L. STARK  
OR VOL 271 - PG 207  
1.00 ACRES | PN. H210002000403  
SURVEY VOL. 11-2-7

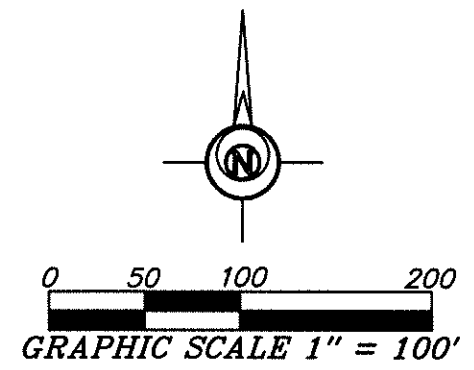

- LEGEND**
- ⊙ 5/8 INCH REBAR W/ID CAP FOUND
  - ⊙ 3/4 INCH REBAR FOUND
  - PK-FD PK NAIL FOUND
  - MAG MAG NAIL SET
  - POB POINT OF BEGINNING
  - POC POINT OF COMMENCEMENT
  - 5/8 INCH REBAR W/ID CAP SET

**NOTE: SURVEY BEARINGS BASED ON OHIO NORTH ZONE STATE PLANE COORDINATES OBTAINED FROM THE OHIO DOT VRS NETWORK**

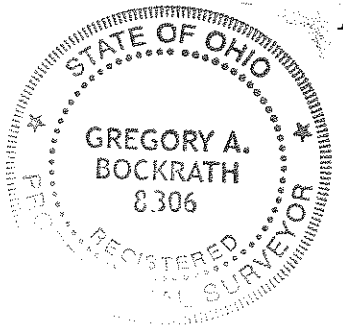

I HEREBY CERTIFY THIS TO BE A SURVEY MADE UNDER MY SUPERVISION AND THAT THE MONUMENTS ARE FOUND AND/OR SET AS INDICATED.

5-28-19  
Date  
Gregory A. Bockrath, P.S.  
Registered Surveyor No. 8306.  
115 S. Fair Avenue, Suite A  
Ottawa, Ohio 45875

THIS SURVEY WAS PERFORMED WITHOUT THE BENEFIT OF A TITLE EXAMINATION. BEYOND THE DEED DOCUMENTS CITED ON THE SURVEY DRAWING THERE MAY BE RECORDED OR UN-RECORDED EASEMENTS AND/OR ENCUMBRANCES BENEFITING OR ENCUMBERING THE SURVEYED PROPERTY WHICH ARE NOT SHOWN ON THIS DRAWING.

FILENAME: 19-139\_WALKUP\_tp-5-22-19.scj DATE: 5/22/19

**SURVEY FOR: ROGER BARTLETT**  
PART OF THE NE 1/4 OF THE NW 1/4 OF SECTION 2, T5N - R1E, MILFORD TOWNSHIP, DEFIANCE COUNTY, OHIO

**Bockrath & Associates**  
Engineering and Surveying, LLC  
115 S. Fair Avenue, Suite A - Ottawa - Ohio  
Phone: 419.523.5789