

DEFIANCE HOSPITAL INC.  
O.R. 101 PG. 0165  
REC. DATE 05-25-2000

STATE OF OHIO  
DEPT. OF TRANSPORTATION  
D.V. 272 PG. 700  
REC. DATE 02-14-1995

OLSON COMMERCIAL  
COLD STORAGE, LTD.  
O.R. 188 PG. 0278  
REC. DATE 4-24-2002

OLSON COMMERCIAL  
COLD STORAGE, LTD.  
O.R. 160 PG. 1070  
REC. DATE 11-06-2001

OLSON ENTERPRISE PARK, LTD.  
O.R. 46 PG. 641  
INCLUDES LAND DESCRIBED IN  
O.R. 160/1070  
REC. DATE 07-13-98

RICKER, RICHARD D.  
& PAMELA S.  
O.R. 308 PG. 2473  
REC. DATE 08-10-2006

PARCEL #4  
18.775 AC.±  
817,835 S.F.

PARCEL #3  
5.000 AC.±  
217,812 S.F.

PARCEL #2  
5.000 AC.±  
217,812 S.F.

PARCEL #1  
6.380 AC.±  
277,913 S.F.

JOANNE PARKER, TRUSTEE  
O.R. 331 PG. 1254  
REC. DATE 01-23-2009

JOANNE PARKER, TRUSTEE  
O.R. 331 PG. 1254  
REC. DATE 01-23-2009

SOUTHERLY LINE OF A PARCEL OF  
LAND AS DESCRIBED IN VOL. 265,  
PG. 273, D.C.D.R.

EASTERLY LINE OF A PARCEL OF  
LAND AS DESCRIBED IN VOL. 265,  
PG. 273, D.C.D.R.

C/L CURVE DATA

CURVE	ARC LENGTH	RADIUS	DELTA ANGLE	CHORD BEARING	CHORD LENGTH
C1	943.36'	603.11'	89°37'10"	N 45°36'06" E	850.09'
C2	223.44'	603.11'	21°13'37"	N 11°24'19" E	222.16'

SUBJECT PROPERTY:  
CITY OF DEFIANCE VOL. 265 PG. 273  
INCLUDES LAND DESCRIBED IN  
O.R. 188 PG. 0278 REC. DATE 01-06-1993  
CONTAINING: 1,531,372 S.F. OR 35.155 AC.±

- LEGEND:**
- FOUND MONUMENT BOX
  - ⊙ FOUND IRON PIPE
  - ⊙ FOUND IRON PIN
  - ⊙ FOUND BENT IRON PIPE
  - ⊙ FOUND BENT IRON PIN REPLACED WITH CAPPED IRON REBAR
  - I.P.S. SET CAPPED IRON REBAR
  - (M.) = MEASURED DISTANCE
  - (D.) = DEED DESCRIPTION DISTANCE
  - (PS) = DISTANCE FROM PREVIOUS SURVEY BY OTHERS
  - (PLANS) = R/W PLANS PROVIDED BY OHIO DEPARTMENT OF TRANSPORTATION
  - D.C.D.R. = DEFIANCE COUNTY DEED RECORDS

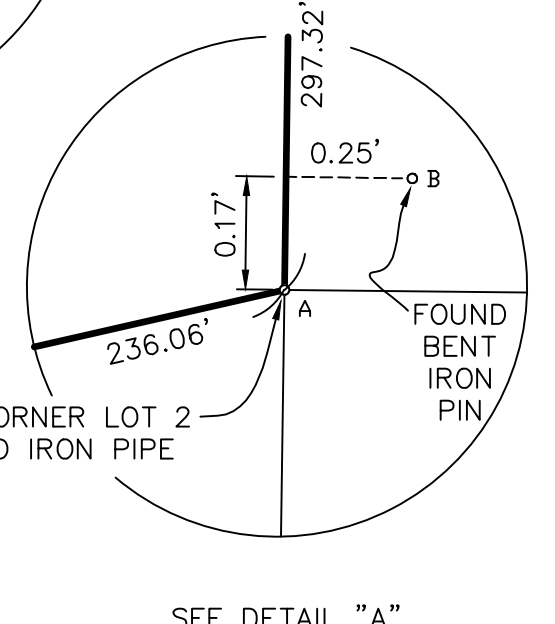
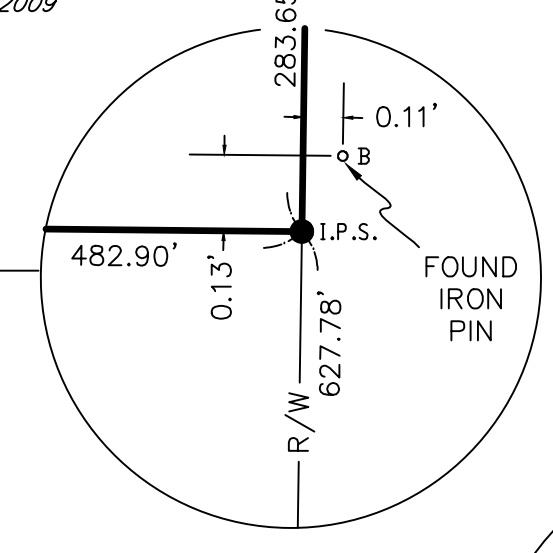

I HEREBY CERTIFY THAT THE INFORMATION SHOWN HEREON IS THE RESULT OF A TRUE AND ACCURATE BOUNDARY SURVEY PERFORMED UNDER MY SUPERVISION DURING SEPTEMBER, 2014

*Robert E. Brazier*  
Robert E. Brazier  
Professional Surveyor No. 8109

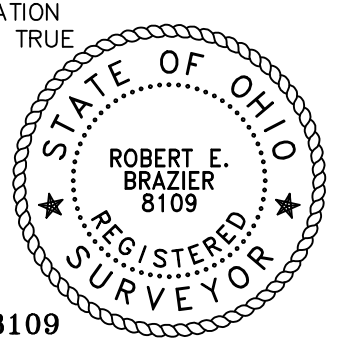

**REVISION**

DATE	DESCRIPTION

SHEET 1 of 1

**JOB NAME:**  
LATCHAW DRIVE PARCEL SPLIT

DRAWING NAME: 2075 LATCHAW.dwg	CLIENT NAME: CITY OF DEFIANCE
JOB NUMBER: 146502075	DESCRIPTION: BOUNDARY SPLIT
SCALE: 1" = 100'	DRAWN BY: PJ
DATE: 09/15/2014	SURVEY BY: PJ
	CHECKED BY: REB

**PARCEL SPLIT SURVEY**

BEING PART OF THE N.E. 1/4, SECTION 22, T-4-N, R-4-E, NOBLE TOWNSHIP, CITY OF DEFIANCE, DEFIANCE COUNTY, OHIO.

PREPARED FOR THE CITY OF DEFIANCE AT THE REQUEST OF LEE RAUSCH, P.E.

# Garcia Surveyors, Inc.

P.O. Box 2628  
Whitehouse, OH 43571  
Phone: (419) 877-0400  
Fax: (419) 877-1140  
E-Mail: tony@garciasurveyors.com

1210 W. High Street  
Bryan, OH 43506  
Phone: (419) 438-8924  
Fax: (419) 877-1140  
E-Mail: pjohanson@garciasurveyors.com