

Defiance County
Sanitary Sewer Use Regulations

Rules, Regulations, Procedures and General Specifications
Governing Sanitary Sewage as established under authority of
Section 6117 of the Ohio Revised Code.

Accepted by the Board of County Commissioners
on December 23, 2021

Poggemeyer Design Group, A Kleinfelder Company

DEFIANCE COUNTY, OHIO
“SANITARY REGULATIONS”

Table of Contents

| | | |
|--------------|---|---------|
| Section 1.00 | Sewer Definitions..... | Page 1 |
| Section 2.00 | Administration of Public Sewers | Page 6 |
| Section 3.00 | Building Sewers and Connections | Page 8 |
| Section 4.00 | Sanitary Sewer Regulations and Charges | Page 12 |
| Section 5.00 | Sanitary Sewer Service Charges | Page 18 |
| Section 6.00 | Use of Public Sewers | Page 20 |
| Section 7.00 | Industrial/Commercial Users Wastewater Pretreatment Standards | Page 22 |
| APPENDIX A | Procedures and Requirements: Tap Connections | |
| APPENDIX B | Procedures in the Construction of Sanitary Sewage Improvement | |
| APPENDIX C | Rates and Fees | |
| APPENDIX D | Flow Meters | |
| APPENDIX E | Resolutions Resolution approving Regulations Resolution setting rates | |
| APPENDIX F | Sanitary Sewer Connection Request Form / Details | |

**SECTION 1.00
SEWER DEFINITIONS**

| | | | |
|------|--|------|--|
| 1.01 | Administrator. | 1.29 | Non-Industrial User |
| 1.02 | Application | 1.30 | NPDES Permit |
| 1.03 | Board of Health | 1.31 | OEPA |
| 1.04 | Biochemical Oxygen Demand (BOD) | 1.32 | Operation |
| 1.05 | Building Drain | 1.33 | Owner or Person |
| 1.06 | Building Sewer | 1.34 | pH |
| 1.07 | Chemical Oxygen Demand (COD) | 1.35 | Pollutant |
| 1.08 | Combined Sewers | 1.36 | Pre-treatment |
| 1.09 | Commercial | 1.37 | Private Sewer |
| 1.10 | Compatible Pollutant | 1.38 | Public Sewer |
| 1.11 | County | 1.39 | Public Sewers or Public Sewage System |
| 1.12 | Debt Charge | 1.40 | Replacement |
| 1.13 | Department of Health | 1.41 | Residential User |
| 1.14 | Director of Defiance County Wastewater Operations | 1.42 | Review Fees |
| 1.15 | Domestic | 1.43 | Sanitary Sewage |
| 1.16 | EDU | 1.44 | Sanitary Sewer |
| 1.17 | Environmental Protection Agency | 1.45 | Sanitary Sewer Charges |
| 1.18 | Floatable Grease | 1.46 | Slug |
| 1.19 | Garbage | 1.47 | Sewage |
| 1.20 | Grease Interceptor | 1.48 | Wastewater Treatment Plant – Wastewater Treatment Works |
| 1.21 | Incompatible Pollutant | 1.49 | Shall; May |
| 1.22 | Industry | 1.50 | Storm Sewage |
| 1.23 | Industrial Wastes | 1.51 | Storm Sewer / Drain |
| 1.24 | Institutional/Governmental | 1.52 | Surcharge |
| 1.25 | Maintenance | 1.53 | Suspended Solids |
| 1.26 | MGD | 1.54 | Unpolluted Water |
| 1.27 | MG/l | 1.55 | User – User Charge / Class |
| 1.28 | Natural Outlet | 1.56 | Watercourse |

Unless the context specifically indicates otherwise, the meaning of terms shall be as follows:

1.01 ADMINISTRATOR

“Administrator” means the Administrator of the Environmental Protection Agency, or any person authorized to act for him.

1.02 APPLICATION

As used in these Sanitary Regulations, the following terms shall have the meanings respectively ascribed to them.

1.03 BOARD OF HEALTH

“Board of Health” means the County Board of Health.

1.04 BIOCHEMICAL OXYGEN DEMAND (BOD)

“Biochemical Oxygen Demand (BOD)” means the quantity of oxygen utilized in the biochemical oxidation of organic matter under standard laboratory procedure in five days at twenty degrees Centigrade, expressed in milligrams per liter.

1.05 BUILDING DRAIN

“Building drain” means that part of the lowest horizontal piping of a drainage system which receives the discharge from soil, waste, and other drainage pipes inside the walls of the building and conveys it to the building sewer, beginning three feet outside the building wall.

1.06 BUILDING SEWER

“Building sewer” means the extension from the building drain to the public sewer or other place of disposal.

1.07 CHEMICAL OXYGEN DEMAND

“Chemical Oxygen Demand” (COD) means the equivalent quantity of oxygen used in the chemical oxidation of organic matter present in water and wastewater. Oxidation is accomplished using a strong chemical oxidizing agent in an acidic medium.

1.08 COMBINED SEWERS

“Combined sewers” means sewers designed to carry sanitary sewage, storm sewage, or industrial wastes, or any combination of the three.

1.09 COMMERCIAL

“Commercial” means a user of wastewater treatment works not in the “domestic” or “industry” classifications as defined herein.

1.10 COMPATIBLE POLLUTANT

“Compatible pollutant” means a waste constituent which does not interfere with the operation or performance of the wastewater treatment works and plant and includes BOD, suspended solids, pH, fecal coliform bacteria, Phosphorus, Ammonia, Oil and Grease, and any additional pollutants identified in the NPDES Permit if the publicly owned treatment works was designed to treat such pollutants

1.11 COUNTY

“County” means Defiance County, Ohio.

1.12 DEBT CHARGE

“Debt charge” means a charge levied against sewer users for the recovery of all or a portion of the non-grant funded portion of the capital costs of the wastewater treatment works.

1.13 DEPARTMENT OF HEALTH

“Department of Health” means the Ohio State Department of Health.

1.14 DIRECTOR OF DEFIANCE COUNTY WASTEWATER OPERATIONS

“Director of Defiance County Wastewater Operations” means the Director of the Defiance County Wastewater Operations or the authorized deputy, agent, or representative.

1.15 DOMESTIC

“Domestic” means a residential user of the wastewater treatment works. Domestic wastes from industries are defined as wastes originating from sanitary conveniences. Domestic wastes do not include trade or process wastes.

1.16 EDU

“EDU” - Equivalent dwelling unit = 150 gpd.

1.17 ENVIRONMENTAL PROTECTION AGENCY

“Environmental Protection Agency” means the Federal, State (or United States) Environmental Protection Agency, or any person authorized to act for that agency.

1.18 FLOATABLE GREASE

“Floatable grease” means oil, fat, or grease in a physical state such that it will separate by gravity from wastewater by treatment in an approved pretreatment facility.

1.19 GARBAGE

“Garbage” means solid wastes from the preparation, cooking, and dispensing of food and from the handling, storage, and sale of produce.

1.20 GREASE INTERCEPTOR

“Grease Interceptor” means a structure designed to remove grease from sanitary sewer flows.

1.21 INCOMPATIBLE POLLUTANT

“Incompatible pollutant” means any pollutant which is not a compatible pollutant.

1.22 INDUSTRY

“Industry” means a manufacturing activity identified as a “Division A, B, D, E, or I” industry, as defined in the Office of Management and Budget’s Standard Industrial Classification Manual, 1972, as amended and supplemented. However, any industry, as previously defined in this paragraph, may be excluded from the “industry” category if it discharges non-process, segregated wastes or wastes from sanitary conveniences.

1.23 INDUSTRIAL WASTES

“Industrial wastes” means the wastewater from industries, as defined herein, as distinct from segregated domestic wastes or wastes from sanitary conveniences. Discharging waste resulting from manufacturing activities involving the mechanical or chemical transformation of materials or substance into other products. These activities occur in establishments usually described as plants, factories or mills and characteristically use power-driven machines and materials handling equipment.

1.24 INSTITUTIONAL/GOVERNMENTAL

“Institutional/Governmental” user means hospitals, nursing homes, schools, city, county, state or federal building or facilities that discharge wastewater into the public wastewater treatment system, works and facility.

1.25 MAINTENANCE

“Maintenance” means upkeep and repair costs required to maintain the sewer system structures and equipment in efficient operating condition during the service life of such works.

1.26 MGD

“mgd” means one million gallons per day.

1.27 MG/l

“mg/l” means milligrams per liter.

1.28 NATURAL OUTLET

“Natural outlet” means any outlet into a watercourse, pond, ditch, lake, or other body of surface or ground water.

1.29 NON-INDUSTRIAL USER

“Non-industrial user” means a user of the wastewater treatment works not in the “industrial user” classification, as defined herein.

1.30 NPDES PERMIT

“NPDES Permit” means the National Pollutant Discharge Elimination System permit for a treatment plant.

1.31 OEPA

“OEPA” means the Ohio Environmental Protection Agency.

1.32 OPERATION

“Operation” means any physical and mechanical actions, processes, or functions required to efficiently operate the sewer system.

1.33 OWNER OR PERSON

“Owner” or “person” means any individual, firm, company, industry, association, society, corporation, or group.

1.34 pH

“pH” means the logarithm of the reciprocal of the hydrogen-ion concentration.

1.35 POLLUTANT

“Pollutant” means any noxious chemical or other refuse material or constituent that impairs the purity of water.

1.36 PRETREATMENT

“Pretreatment” means the treatment of wastewater from users before introduction into the sewer system.

1.37 PRIVATE SEWER

“Private sewer” means any extension of the wastewater treatment works which is not a public sewer.

1.38 PUBLIC SEWER

“Public sewer” means a sewer in which all owners of abutting properties have equal rights and is controlled by public authority.

1.39 PUBLIC SEWERS OR PUBLIC SEWAGE SYSTEM

“Public sewers” or “public sewage system” includes all sewers which are controlled by public authority.

1.40 REPLACEMENT

“Replacement” means expenditures for obtaining and installing equipment, accessories, or appurtenances which are necessary to maintain the capacity and performance during the service life of the treatment works for which such works were designed and constructed.

1.41 RESIDENTIAL USER

“Residential user” means any user of the system generating domestic wastewater originating at a home or residence.

1.42 REVIEW FEES

“Review fees” means fees required to be paid to the County for any plan review at the current established fee schedule.

1.43 SANITARY SEWAGE

“Sanitary sewage” means the waste from water closets, urinals, lavatories, sinks, bathtubs, showers, household laundries, basement/cellar floor drains, garage floor drains, bars, and soda fountains, cuspidors, refrigerator drips, drinking fountains and such other commercial and industrial wastes as are not “clean waste waters”.

1.44 SANITARY SEWER

“Sanitary sewer” means a sewer that carries liquid and water-carried wastes from residences, commercial buildings, industries, and institutions, together with minor quantities of ground, storm, and surface waters that are not admitted intentionally.

“Sewer” means a pipe or conduit that carries wastewater or drainage water.

1.45 SANITARY SEWER CHARGES

“Sanitary sewer charges” means the aggregate of various components of billing charges, user charges, and extra strength surcharges.

1.46 SLUG

“Slug” means any discharge of water or wastewater which in concentration of any given constituent or in quantity of flow exceeds for any period of duration longer than fifteen minutes more than five times the average twenty-four-hour concentration or flows during normal operation and shall adversely affect the wastewater treatment works.

1.47 SEWAGE

“Sewage” means a combination of water-carried wastes from residences, business buildings, institutions, and industrial establishments, together with such surface and ground water as may be present.

1.48 WASTEWATER TREATMENT PLANT – WASTEWATER TREATMENT WORKS

“Wastewater treatment plant” or “WWTP” means that portion of the wastewater treatment works required to treat wastewater and dispose of the effluent.

“Wastewater treatment works” or “works” means the structures, equipment, parcels of land, easements, and processes required to collect, carry away, and treat wastewater and dispose of the effluent of the sewer users. Wastewater treatment works shall include sanitary sewers and intercepting sewers but shall not include storm sewers.

1.49 SHALL; MAY

“Shall” is mandatory; “may” is permissible.

1.50 STORM SEWAGE

“Storm sewage” means water flowing from surface drainage, rainwater from roofs, subsoil drainage, cistern overflow, foundation drains, water from condensers, cooling systems, and other water which is free from sanitary sewage or industrial wastes.

1.51 STORM SEWER/DRAIN.

“Storm drain” or “storm sewer” means a drain or sewer for conveying water, ground water, subsurface water, or unpolluted water from any source.

1.52 SURCHARGE

“Surcharge” means charges exceeding the domestic fee charges for service due to excess loadings above domestic waste in concentration or pounds being discharged to the system. These are at the established current rate. Surcharges are calculated on the peak monthly discharge for all days of the month.

1.53 SUSPENDED SOLIDS

“Suspended solids” means total suspended matter that either floats on the surface of, or is in suspension in, water, wastewater, or other liquids and that is removable by laboratory filtering as prescribed in “Standard Methods for the Examination of Water and Wastewater” and referred to as nonfilterable residue.

1.54 UNPOLLUTED WATER

“Unpolluted water” means water of quality equal to or better than the effluent criteria delineated in the NPDES permit or water that would not cause violation or receiving water quality standards and would not be benefitted by discharge to the sanitary sewers and wastewater treatment facilities provided.

1.55 USER – USER CHARGE / CLASS

“User” means any building, structure, or other facility either directly or indirectly connected with the sanitary sewer system.

“User charge” means a charge levied on users of the wastewater treatment works for the cost of construction operation, maintenance, and replacement of the wastewater treatment works.

“User class” means any class of users of the wastewater facilities.

1.56 WATERCOURSE

“Watercourse” means a channel in which a flow of water occurs, either continuously or intermittently.

**SECTION 2.00
ADMINISTRATION OF PUBLIC SEWERS**

| | | | |
|------|---|------|---|
| 2.01 | Director of Defiance County Wastewater Operations; duties. | 2.04 | Duty of Director of Defiance County Wastewater Operations |
| 2.02 | Permits for private sewer connecting to public sewer; records | 2.05 | Destruction of property. |
| 2.03 | Right of entry. | 2.06 | Violations. |
| | | 2.07 | Penalty. |
| | | 2.08 | Possible invalidities and other agreements. |

2.01 DIRECTOR OF DEFIANCE COUNTY WASTEWATER OPERATIONS - DUTIES.

The Director of Defiance County Wastewater Operations shall be employed by the County Commissioners or shall be an authorized representative. The appointment shall be fixed by the Commissioners and shall be paid from the Sewer Fund for their services. The Director shall be an employee of the County or be employed as a Consultant. The Director of Defiance County Wastewater Operations shall have charge of the operation and maintenance of Sewage Treatment Plants and collection systems, under the direction of the County Commissioners.

2.02 PERMITS FOR PRIVATE SEWER CONNECTION TO PUBLIC SEWER; RECORDS.

- (a) The Director shall have charge of the issuing of permits for the construction of sewers that connect with the public sewage system and shall inspect all such sewer construction.
- (b) The Director shall have charge of the issuing of permits which determine the size, location, and grade for all private sewers which connect with the public sewer system and shall determine when a property is reasonably accessible to a sewer. In case of a disagreement of the availability of a sewer to a property, the County shall investigate and make such decision as is warranted. The form of the permit shall be determined by the Director and approved by the County.
- (c) The Director shall keep complete records of all permits issued and shall be responsible for the recording of all information relative to their work.

2.03 RIGHT OF ENTRY.

In the event that the Director or any other duly authorized employee of the County (or Engineering Consultant), bearing proper credentials and identification, is denied entry upon any property for the purpose of inspection, observation, measurement, sampling, and testing, then the Director is hereby empowered to forbid sewage or materials of any nature from being discharged into the public sewers from such property. However, the Director shall give notice to the person of their intentions to so inspect the premises, which notice shall state the time, which must be a reasonable time, for the inspection.

2.04 DUTY OF DIRECTOR OF DEFIANCE COUNTY WASTEWATER OPERATIONS.

The Director shall establish grades, sizes, and other details relative to the construction, maintenance, and repair of all public sewers. The Director shall be in charge of all construction and maintenance of all public sewers and shall provide and keep the necessary books and maps which show accurately the location of all public sewers and sewer connections. The Director shall revise such records as connections are made, sewers are constructed, or information relative to existing sewers if determined, (or designated authorized representative or Engineering Consultant).

2.05 DESTRUCTION OF PROPERTY.

No person shall willfully break, damage, destroy, deface, or tamper with any structure, appurtenance, or equipment

which is a part of the public sewage system or Sewage Treatment Plant.

2.06 VIOLATIONS.

Any person violating any provision of the sanitary regulations shall become liable to the County for any expense, loss, or damage occasioned the County by reason of such violation

2.07 PENALTY.

Whoever violates any provision of the sanitary regulations where no other penalty is provided, shall be fined one hundred dollars (\$100.00) minimum and up to ten thousand dollars (\$10,000) maximum. A separate offense shall be deemed committed each day during or on which a violation occurs or continues.

2.08 POSSIBLE INVALIDITIES AND OTHER AGREEMENTS.

The several parts of the foregoing rules, regulations, procedures, and general specifications are hereby declared separate and in the event any provision or part thereof shall be declared void and ineffective for any cause, such declaration shall not affect nor render invalid any other provision or part hereof.

Nothing in these rules, regulations, procedures, and general specifications shall prohibit the Board of County Commissioners or the Director of Defiance County Wastewater Operations from entering into an agreement with any person, firm, corporation, or governmental agency for the furnishing of a service or performance of any act not specifically mentioned in these rules, regulations, procedures, and general specification.

**SECTION 3.00
BUILDING SEWERS AND CONNECTIONS**

| | | | |
|------|--|------|---|
| 3.01 | Permit required. | 3.09 | Installation. |
| 3.02 | Permit time limit; extension of time; non-refundable permit fee. | 3.10 | Gravity flow or artificial lifting. |
| 3.03 | Cost and expenses; County held harmless. | 3.11 | Excavation; pipe laying; backfill; inspections |
| 3.04 | One sewer for two buildings. | 3.12 | Joints and materials. |
| 3.05 | Public Sewer Connections. | 3.13 | Clean-outs |
| 3.06 | Old sewers for new buildings. | 3.14 | Testing. |
| 3.07 | Material standards; joints. | 3.15 | Connection to public sewer. |
| 3.08 | Slope; diameter. | 3.16 | Connection to be supervised. |
| | | 3.17 | Excavation warnings; restoration of public property |
| | | 3.18 | Penalty. |

3.01 PERMIT REQUIRED.

- (a) No unauthorized person shall connect or disconnect any public sewer or appurtenance thereto, without first obtaining a written permit from the Director of Defiance County Wastewater Operations or the alternate representative.
- (b) The owner or their agent shall make application on a special form furnished by the County. The permit application shall be supplemented by any plans, specifications, or other information considered pertinent in the judgement of the Director and/or Commissioners.

3.02 PERMIT TIME LIMIT; EXTENSION OF TIME; NON-REFUNDABLE PERMIT FEE.

The permit, when signed by the Director, shall be applicant's authority to connect or disconnect the public sewer and it shall be valid for sixty days unless the Director grants an additional thirty-day extension due to unforeseen circumstances.

With the exception of the County's public sewer causing the failure of the applicant's sewer, the permit and inspection fee for residential, commercial, and industrial connections or disconnections to the sewer system in Section 5.00 is not refundable even though the sewer permit is not used to connect or disconnect a sewer.

A tap charge shall be charged to any new user who heretofore has not been assessed for the cost of or has not paid in any way for the sanitary sewer.

Residential. For a residential lot of any size, the property owner shall pay a charge as established by the County Commissioners.

Commercial and Industrial. Commercial and industrial users shall pay a charge as established by the County Commissioners for property abutting the sewer and for property not abutting the sewer but having access to the sewer through other property by easement.

3.03 COST AND EXPENSES; COUNTY HELD HARMLESS.

All costs and expense incidental to the installation and connection of a building sewer shall be borne by the owner. The owner shall hold the County harmless from any loss or damage that may directly or indirectly be occasioned by the installation of the building sewer.

3.04 ONE SEWER FOR TWO BUILDINGS.

A separate and independent building sewer shall be provided for every building where possible. However, upon a written consent of the Director and as approved by County Commissioners, two buildings may use the same building sewer only if unique conditions justify such consideration and separate connections are not feasible.

Before such permission is granted an agreement running with the land establishing the relationship between the properties must be given to the Commissioners. (Recorded Easement).

3.05 PUBLIC SEWER CONNECTIONS

No sewer shall be constructed to connect with a public sewer, nor shall any connection be made to a public sewer within the County until the written permission of the Director has been obtained by the person, firm or corporation to perform the work. An application for a permit shall be signed by the owner, agent, or lessee of the property for which the connection is to be made and by the person, firm or corporation to perform the work, and shall describe the property, state the fixtures to be connected and shall be accompanied by the appropriate fees.

No house sewer shall be constructed, or connection made to a public sewer by any person who has not been authorized.

Written permission to construct a house sewer or to make a connection to a public sewer shall specify the permissible use of such house sewer and connection and such specifications shall be governed by the following requirements:

1. Sewage, including wastes from water closets, urinals, lavatories, sinks, bathtubs, showers, laundries, floor drains, garage floor drains, bars, soda fountains, cuspidors, refrigerator drips, drinking fountains, and other objectional wastes shall be discharged into a sanitary sewer and in no case into a storm water sewer.
2. Industrial waste shall not be discharged into a storm water but may be discharged into a sanitary sewer if the waste is of such character as not be detrimental to the sewer system or the sewage treatment works. Where such waste is detrimental to the sewer system or sewage treatment works, it shall be otherwise disposed of in a satisfactory manner or so improved in character as not be detrimental.
3. Surface water, roof runoff, subsoil drainage, building foundation drainage, cistern overflow, clean water from condensers, wastewater from water motors and elevators and any other clean and unobjectionable waste shall be discharged into a storm water and never into a sanitary sewer.
4. Connection with a cesspool or a privy vault shall not be made into a sanitary, combined or storm water sewer.
5. A trap for the interception of grease and oil shall be provided on a connection from any commercial hotel, including restaurant, club, or institutional kitchen and from a public garage or automobile washing station.
6. No person shall discharge into a house sewer or tap a house sewer for the purpose of discharging into it any waste or drainage water prohibited by the provisions of this section. Any existing connection in violation of this section shall be abandoned and removed.
7. The Director is authorized and directed to adopt and enforce specifications and regulations in accordance with the provisions of this chapter for the purpose of providing control of the installation of sewer connections and inspection thereof. The Director shall maintain accurate and complete records of all permits issued for and inspections made of the construction of house sewers and connections to the public sewers. The Director shall also require the abandonment and removal of connections to the public sewers which violate this chapter.

3.06 OLD SEWERS FOR NEW BUILDINGS.

Old sewers may be used in connection with buildings only when they are found, on examination and properly tested with the Director (or authorized representative) present, to meet all the requirements of these Regulations.

3.07 MATERIAL STANDARDS; JOINTS.

The building sewer shall be PVC pipe conforming to ASTM 3034 SDR35 or any other suitable material approved by the Director and the Commissioners.

Joints shall be tight and waterproof.

3.08 SLOPE; DIAMETER.

The size and slope of the building sewer shall be subject to the approval of the Director, or authorized representative, but in no event shall the diameter be less than six inches. The slope of such pipe shall be not less than one-eighth inch per foot.

3.09 INSTALLATION.

Whenever possible the building sewer shall be brought to the building at an elevation three (3) feet below the finished grade. No building sewer shall be laid parallel to or within three feet of any bearing wall, which might thereby be weakened. The depth shall be such to afford protection from frost. The building sewer shall be laid in uniform grade in straight alignment so far as possible, changes in direction shall be made only by properly curved pipe and fittings, without using 90° elbows.

3.10 GRAVITY FLOW OR ARTIFICIAL LIFTING.

In all building in which any building drain is too low to permit gravity flow to the public sewer, sanitary sewage carried by such drain shall be lifted by an approved artificial means and discharged to the building sewer at owners' expense.

3.11 EXCAVATIONS; PIPE LAYING; BACKFILL; INSPECTIONS.

- (a) All excavations required for the installation of the building sewer shall be open trench work unless otherwise approved by the Director of Defiance County Wastewater Operations.
- (b) Pipe laying and backfill shall be performed in accordance with "Construction and Material Specifications" of the State Department of Transportation or the American Society for Testing Materials (ASTM) Specifications (C12) latest edition, except that no backfill shall be placed until the work has been inspected.
- (c) The Director or any employee of the Director shall make inspection, within twenty-four hours after notice is given to the Director of Defiance County Wastewater Operations that the installation is ready for inspection, unless such inspection would fall on a Saturday, Sunday, or Holiday. In such an event, the inspection would be conducted on the next regular working day of Monday through Friday between the hours of 9:00 a.m. to 3:00 p.m.

3.12 JOINTS AND MATERIALS

Plastic pipe shall conform to provisions of ASTM 3034 with a SDR of 35. Joints shall be push type and shall be in accordance with the manufacturer's specifications. The bell shall be an integral part of the pipe and shall have a locked-in rubber sealing ring. The bell and rubber ring shall conform to ASTM D-3212.

3.13 CLEANOUTS.

Six-inch (6") cleanouts shall be installed within five feet (5') of the building foundation wall and at 100 feet (100') intervals and at any change in direction greater than 45°. They shall extend above the finished grade surface. A removable waterproof cap shall be placed at the top of the cleanout. Materials for the cleanout shall conform to Section 3.12. A 2' ½" Rebar shall be located adjacent to the cleanout.

3.14 TESTING

Testing of the building sewer is required and is to be observed by the Director of Defiance County Wastewater Operations Department.

3.15 CONNECTION TO PUBLIC SEWER

The connection of the building sewer into the public sewer shall be made at the "Wye" branch if such branch is available at a suitable location. When no properly located "Wye" is available, a neat hole may be cut into the public sewer at the location specified by the Director on the uppermost side. If this is not possible, entry shall be made at the highest point possible on the side. A smooth, neat joint shall be made, and the connection secure and watertight, by use of a saddle or similar device.

3.16 CONNECTION TO BE SUPERVISED.

The applicant for the building sewer permit shall notify the Director of Defiance County Wastewater Operations when the building sewer is ready for inspection and connection to the public sewer.

The connection shall be made under the supervision of the Director or an employee of the Director of the Defiance County Wastewater Operations Department, within the time set out in Section 3.11.

3.17 EXCAVATION WARNINGS; RESTORATION OF PUBLIC PROPERTY.

All excavation for building sewers shall be adequately guarded with barricades and lights so as to protect the public from hazards. Streets, sidewalks, parkways, and other public property disturbed in the course of the work shall be restored in a manner satisfactory to the Director and the County Commissioners or properly steel plated with appropriate night lighting. All permits shall be obtained from the Township and County Engineer.

3.18 PENALTY

(Editor's Note: See Section 2.07 for penalties applicable to this chapter if no other penalty is provided.)

**SECTION 4.00
SANITARY SEWER REGULATIONS AND CHARGES**

- | | | | |
|------|---------------------------------------|------|---|
| 4.01 | Control of wastewater discharges. | 4.03 | Penalties. |
| 4.02 | Powers and authority of the Director. | 4.04 | Validity. |
| | | 4.05 | Rules, Regulations and Procedures in Force. |
-

4.01 CONTROL OF WASTEWATER DISCHARGES.

Prohibited Discharges:

The discharge of non-acceptable industrial wastes into the sewerage system, whether directly or indirectly, is prohibited. Non-acceptable wastes shall be the following described substances: materials, waters, or wastes.

Substances Limited:

The following described substances, materials, waters, or wastes shall be limited in discharges to County system to concentrations or quantities which will not harm either the sewers, wastewater treatment process, or equipment, will not have an adverse effect on the receiving stream, or will not otherwise endanger lives, limb, public property, or constitute a nuisance. The County may set limitations, lower than the limitations established in the regulations below, if in its opinion more severe limitations are necessary to meet the above objectives. Deliberate dilution with unpolluted water to meet the concentrations established in the regulations below shall not be acceptable. In forming its opinion as to the acceptability, the County will give consideration to such facts as the quantity of such waste in relation to flows and velocities in the sewer's materials of construction of the sewers, the wastewater treatment process employed, capacity of the wastewater treatment plant, and other pertinent factors. The limitations or restrictions on materials or characteristics of waste or water discharged to the sanitary sewer which shall not be violated without approval of the County are as follows:

1. Any liquid or vapor having a temperature higher than 140 degrees Fahrenheit (5 degrees Centigrade).
2. Any water or waste containing fats, wax or similar substances which may solidify or become viscous at a temperature between 32- and 140-degrees Fahrenheit.
3. Any water or wastes containing grease and emulsified oil.
4. Any gasoline, benzene, naphtha, fuel oil or mineral oil or other flammable or explosive liquids, solids, or gas.
5. Any garbage that has not been properly comminuted.
6. Any intermittent or continuous contributions of substances in quantities or of such size capable of causing obstruction to the flow in sewers, or other interference with the proper operations of the sewage treatment plant, such as, but not limited to, ashes, sand, mud, cinders, straw, shavings, metal, glass, rags, feathers, tar, plastics, wood, unground garbage, etc.
7. Solid or viscous substances in quantities or of such size capable of causing obstruction to the flow in sewers or other interference with proper operation of the wastewater facilities such as, but not limited to, ashes, bones, cinders, sand, mud, straw, shavings, metal, glass, rags, feathers, tar, plastics, wood, undergrounded garbage, whole blood, paunch manure, hair and fleshing, entrails and paper dishes, cups, milk containers, etc., either whole or ground by garbage disposals. Direct discharges of such materials as tar, asphalt, paint, and waxes also shall be prohibited because they may adhere to sewers and thus reduce the effective size of the pipe.
8. Any excess amounts of phenols, or similar substances, which cause the County to be in violation of receiving water quality objectives established by the State or any other agency of jurisdiction.
9. Any waters or wastes, acid or alkaline in reaction, and having corrosive properties capable of causing damage to or hazard in the sewers or to the structures, equipment, and personnel of the County. Free acids and alkalis of such wastes shall be neutralized, at all times, within a permissible range of pH, between 5.5 and 8.5.
10. No person, firm or corporation shall be permitted to connect to or discharge wastewater to the County sewage

system unless it has been determined by the County that there is sufficient capacity in the system to collect, convey and treat the proposed wastewater discharge of such person, firm or corporation.

11. Any waters or wastes discharged by nonindustrial users, and non-permitted industrial users containing solids, liquids, or gases in sufficient quantity, either singly or by interaction with other wastes to injure or interfere with any wastewater treatment process, constitute a hazard to humans or animals, create a public nuisance, or create any hazard in the receiving waters of the wastewater treatment plant including but not limited to cyanides, hexavalent chromium, copper, zinc, cadmium, nickel, and phenols in the wastes as discharged to the public sewer. The following concentrations shall not be exceeded in nonindustrial and non-permitted industrial user's wastes discharged to the public sewers:

Total cyanide (CN), 0.34 milligrams per liter (mg/l)
Chromium, total, 11.26 mg/l
Copper, 1.75 mg/l
Zinc, 5.63 mg/l
Cadmium, 1.02 mg/l
Nickel, 0.816 mg/l
Phenols, 0.005 mg/l
Lead, 0.548 mg/l
Mercury, 0.00615 mg/l
Silver, 0.2 mg/l
Hydrogen sulfide, 10 mg/l
Sulfur dioxide gas, 5 mg/l

These maximum concentrations may be changed as necessary by the County or State regulatory agencies based on new information concerning inhibitory substances or to protect treatment plant processes. Industrial discharges covered by Federal pretreatment requirements shall meet those limitations required in **Section 7.00**

12. Any cyanides in excess of two milligrams per liter as Cn in the wastes from any outlet in the public sewer,
13. Any toxic, noxious, or malodorous gas or substances, which either singly, or by interaction with other wastes, is capable of causing interference with the wastewater treatment process, hazard to life or public nuisance or which prevents entry into sewers for maintenance and repair.
14. Any radioactive wastes or isotopes.
15. Any storm water, surface water, ground water, roof run-off water, subsurface drainage, uncontaminated cooling water or unpolluted industrial process waters shall be discharged to a natural outlet or storm sewer.

(a) Normal Concentration of Wastes.

- (1) Charges for waste treatment shall apply to wastes not exceeding normal concentrations as follows:
 - A. BOD - 200 milligrams per liter.
 - B. Suspended solids - 240 milligrams per liter.
 - C. Phosphorus - 10 milligrams per liter.
 - D. Ammonia - 15 milligrams per liter.
 - E. Oil and Grease - 50 milligrams per liter.
- (2) Applicable concentrations shall be based on average concentrations, weighted in proportion to volume of flow, determined during each billing period by the most practical method possible. Should the average concentration of any constituent exceed the normal concentration provided in this section, a user charge -extra strength surcharge shall be collected by the County.

(b) Authority for Control of Wastewater Discharges.

If any wastes are discharged, or are proposed to be discharged, to the wastewater treatment works which contain pollutants in excess of normal concentrations as defined above and/or possess characteristics which, in the judgement of the County, may have a deleterious effect upon the wastewater treatment works or receiving waters, including violation of applicable NPDES permit, or which otherwise create a hazard to life or constitute a public nuisance, the County shall:

- (1) Reject the wastes; or
- (2) Require pretreatment to an acceptable condition for discharge to the wastewater treatment works; and/or
- (3) Require control over the quantities and rates of discharge; and/or
- (4) Require payment of surcharges as provided previously to cover the added cost of handling and treatment of the waste.

(c) Industrial Wastes. Refer to Section 7.00.

(d) Submission of Basic Data

Within ninety days after the passage of this chapter, each person whose operation entails the discharge of industrial wastes to a public sewer shall prepare and file with the County, a written statement setting forth the nature of the operation contemplated or presently carried one, the amount and source of water required for use, the proposed point of discharge of said wastes into the wastewater collection system of the County, the estimated amount to be so discharged and a fair statement setting forth the expected bacteria, physical, chemical, toxic and other known characteristics of such wastes. Within a reasonable time of receipt of such statement, it shall be the duty of the County to make an order stating such minimum restrictions as in the judgement of the County may be necessary to adequately guard against unlawful uses of the wastewater system. When it can be demonstrated that circumstances exist which would create an unreasonable burden on the person to comply with this time schedule, a request for extension of time may be presented for consideration of the County. All requests for extension of time shall be submitted in writing, stating the reasons for such a request. Under no circumstances shall extension time exceed sixty days after approval of the extension by the County.

(e) Oil and Grease.

- (1) Flammable waste and grit intercepting facilities must be provided on all building sewers from garages, filling stations, cleaning establishments, and other concerns using volatile oils or solvents. Special pretreatment methods are required for the removal of soluble cutting oils. All grease and oil removal facilities must be approved by the County.
- (2) Grease, Sand and Oil Traps: Grease, oil and sand interceptors shall be provided when in the opinion of the Director, they are necessary for proper handling of liquid wastes containing floating grease or oil in excessive amounts, or any flammable wastes, sand, or other harmful ingredients. (A trap for the interception of grease, oil and mud shall be provided on a connection from a restaurant, club, hotel, residential dwelling consisting of more than 4 units, food, or bakery establishment, commercial or institutional kitchen, public garage, automobile washing station, slaughter or packing house.)

All interceptors shall be of a type and capacity approved by the Director, or authorized representative, and shall be located as to be readily and easily accessible for cleaning and inspections. All interceptors shall be constructed of impervious materials capable of withstanding abrupt and extreme changes in temperature. They shall be of substantial construction; watertight and equipped with easily removable covers which when bolted in place shall be gas tight and watertight. Where installed, all grease, oil and sand interceptors shall be maintained by the

owner(s) at the owner(s) expense, in continuous efficient operation at all times.

In the maintenance of these interceptors, the owner(s) shall be responsible for the proper removal and disposal of appropriate means of the captured material and shall maintain records of the dates and means of disposal, which shall be subject to review by the Director. Any removal and hauling of the collected material must be performed by currently licensed waste disposal firms unless approved otherwise by the Director. Where the potential for the discharge of flammable substances exists, the user may be required to install and maintain an approved combustible gas detention meter.

(f) Sampling and Monitoring

Industrial wastes discharged to the wastewater treatment works shall be subject to periodic inspection with a determination of character and concentration of such wastes. The determination shall be made as often as may be deemed necessary by the County. The user shall be responsible for the cost of collection and testing of the aforementioned samples.

(1) Samples shall be collected in such a manner as to be representative of the composition of the wastes. The sampling shall preferably be accomplished by the use of automatic sampling equipment capable of collecting composite samples. Every care shall be exercised in the collection of samples to ensure their preservation in a state comparable to that at the time the sample was taken.

(g) Control Manhole.

When required by the County, a user shall install one or more suitable structures, together with such necessary flow meters and other appurtenances, in the building sewer(s) to facilitate observation, sampling, and measurement of the wastes. Such structure(s), when required, shall be accessible and safely located and shall be constructed in accordance with plans approved by the County. The structure(s) and appurtenances shall be installed by the user at their expense and shall be maintained by the user so as to be safe and accessible at all times. Flow meters must be tested and calibrated annually at the expense of the owner.

(h) Testing.

(1) All measurements, tests, and analysis of the characteristics of wastes to which reference is made in this chapter shall be determined in accordance with the latest edition of "Standard Methods for Examination of Water and Wastewater," published by the American Public Health Association, unless such standards conflict with regulations promulgated by the U.S. Environmental Protection Agency with 40 CFR 136 - "Guidelines Establishing Test Procedures for the Analysis of Pollutants," in which case the regulations promulgated by the Environmental Protection Agency shall govern. Sampling methods, location, times, duration, and frequencies shall be determined on an individual basis subject to approval by the County or its duly authorized representative.

(2) All costs incident to sampling and analysis shall be borne by the user. Such costs incurred by the County on behalf of the user shall be billed annually to the user, based on the actual cost to the County, plus reasonable overhead. Such billing shall be billed with and be considered a part of the sewer service charge for the period billed.

(i) Discharge of Wastes to Storm Sewers. Are strictly prohibited.

(1) Any waters or wastes containing "odor-producing" substances exceeding limits, which may be established by the Board or any local or State regulatory agencies.

(2) Quantities of flow, concentrations of both, which constitute "slug" as defined herein.

(3) Waters and wastes containing substances which are not amenable to treatment or reduction by the

wastewater treatment processes employed or are amenable only to such degree that the wastewater treatment plant effluent cannot meet the requirements of other agencies having jurisdiction over discharge to the receiving waters.

- (4) Any water or wastes which by interaction with other water or wastes in the public sewer system, release noxious gases, form suspended solids which interfere with the collection system, or create a condition deleterious to structures and treatment processes.

(j) Substances Prohibited.

No person shall discharge or cause to be discharged any of the following described materials into any public sewers (or treatment works):

- (1) Any waters or wastes having a pH lower than 5.5 or higher than 9.0, or having any other corrosive property capable of causing damage to hazard to structures, equipment, and personnel of the wastewater treatment works.
- (2) Any noxious or malodorous gas or substance capable of creating a public nuisance.

(k) Connections Required.

The owner of all houses, buildings, or properties used for human occupancy, employment, recreation, or other purpose, situated within the County, and abutting on any street, alley, right-of-way, or sewer easement in which there is now located or may in the future be located a public sanitary sewer of the County is hereby required to connect such building directly with the proper public sewer in accordance with present County regulations.

(l) When Preliminary Treatment Pre-Treatment Required.

The admission into the public sewers of any waters or wastes having characteristics which vary from normal sewage shall be subject to the review and approval of the County. When necessary, in the opinion of the County, such preliminary treatment facilities as may be needed to control the quantities and rates of discharge or reduce objectionable characteristics or constituents shall be constructed according to plans approved by the County. Where preliminary treatment facilities are provided for any waters or wastes, they shall be maintained continuously in satisfactory and effective operation, by the owner at his expense.

(m) When Private System Required.

Where a public sanitary sewer is not available, the building sewer shall be connected to a private sewage system complying with the requirements of the State of Ohio Environmental Protection Agency (OEPA). No statement contained in this section shall be constructed to interfere with any additional requirements that may be imposed by the Ohio Environmental Protection Agency, or Section 7.00.

(n) Owner's Responsibility.

All costs and expenses incidental to the installation, connection, and maintenance of a building sewer lateral and/or grinder pump, shall be borne by the owner. The owner and/or contractor shall indemnify the County from any loss, damage, or costs that may directly or indirectly be occasioned by the installation and/or maintenance and operation of any building sewer. It shall be understood that the Owner is responsible for the maintenance of the entire building sewer and/or grinder pump to the public sewer, even though a portion of this building sewer was constructed by others.

(o) Notification of Accidental Spills.

When a user of the sewer system discharges substances in violation of subsection (I) and (j) covering

limited and prohibited substances, the discharger shall immediately notify the County and Ohio EPA of the time, location, type, quantity, and concentration of the discharge. Also, advise of what corrective actions are being taken. Notification shall not relieve the violator of legal responsibilities regarding the discharge.

4.02 POWERS AND AUTHORITY OF THE DIRECTOR

1. No person(s) shall maliciously, willfully, or negligently break, damage, destroy, uncover, deface, or tamper with any structure, appurtenance, or equipment which is a part of the wastewater facilities system. Any person(s) violating this provision shall be subject to immediate arrest under charge of disorderly conduct.
2. The Director of Defiance County Wastewater Operations and other duly authorized employees of the County bearing proper credentials and identification shall be permitted to enter all properties for the purposes of inspection, observation, measurement, sampling, and testing pertinent to discharge to the community system in accordance with the provisions of these rules, regulations, and procedures.
3. The Director of Defiance County Wastewater Operations or other duly authorized employees are authorized to obtain information concerning industrial processes which have a direct bearing on the kind and source of discharge to the wastewater collection systems.
4. While performing the necessary work on private properties, the Director of Defiance County Wastewater Operations or duly authorized employees of the County shall observe all safety rules applicable to the premises established by the company, and the company shall be held harmless for injury or death to the County employees, and the County shall indemnify the company against loss or damage to its property by County employees and against liability claims and demands for personal injury or property damage asserted against the company and growing out of the gauging and sampling operation, except as such may be caused by negligence or failure of the company to maintain safe conditions.
5. The Director and other duly authorized employees of the County bearing proper credentials and identification shall be permitted to enter all private properties through which the County holds a duly negotiated easement for the purposes of, but not limited to, inspection, observation, measurement, sampling, repair, and maintenance of any portion of the wastewater facilities system lying within said easement. All entry and subsequent work, if any, on said easement, shall be done in full accordance with the terms of the duly negotiated easement pertaining to the private property involved.

4.03 PENALTIES

1. Any person found to be violating any provisions of these rules, regulations, and procedures shall be served by the County with written notice stating the nature of the violation and providing a reasonable time limit for the satisfactory correction thereof. The offender shall, within the period of time stated in such notice, permanently cease all violations.
2. Any person who continues any violation beyond the time limit provided for, shall be subject to fines, injunctive action, and/or other legal actions under the pertinent sections of the Ohio Revised Code.
3. Any person violating any of the provisions of these rules, regulations, and procedures shall become liable to the County for any expense, loss, or damage occasioned the County by reason of such violation.

4.04 VALIDITY

1. All rules, regulations, and procedures in conflict herewith are hereby repealed.
2. The invalidity of any section, clause, sentence, or provision of these rules, regulations, and procedures shall not affect the validity of any other part which can be given effect without such invalid part or parts.

4.05 RULES, REGULATIONS, AND PROCEDURES IN FORCE

1. These rules, regulations and procedures shall be in full force and effect from and after its passage, approval, recording, and publication as provided by law.

**SECTION 5.00
SANITARY SEWER SERVICE CHARGES**

| | | | |
|------|------------------------|------|---|
| 5.01 | Authority for Charges. | 5.04 | Mailing Bills. |
| 5.02 | Basis of Charges. | 5.05 | Monthly Charges. |
| 5.03 | Delinquent Charges. | 5.06 | Building Sewer Permit Fee. |
| | | 5.07 | Plan Review and Inspection Fee Schedule |

5.01 AUTHORITY FOR CHARGES.

The Board of County Commissioners has the authority to establish and regularly review the monthly sanitary sewer service charge for each individual connection to any and all sanitary sewerage systems operated and maintained by the County Director of Defiance County Wastewater Operations for all expenses incurred by the Director in operating, maintaining, and financing of improvements to the sanitary sewerage systems under this jurisdiction.

5.02 BASIS OF CHARGES.

Monthly unit sewer service charges as established by the Board of County Commissioners are normally billed to the owner of any property connected to a County operated sanitary sewerage system. If the owner of any property elects to have his tenant or lessee pay these charges as they accrue, such tenant or lessee does so as the agent of the owner, and such owner shall be held responsible for unpaid charges. Multi-family residences shall be charged one unit sewer service charge for each single-family unit.

All vacant units in a multi-family housing or vacant dwellings, trailers or condominiums shall be charged one full unit. No discounted charges will be permitted for homes or dwellings temporarily vacated during absence of the resident.

All vacant lots in platted subdivisions with improved streets and utilities shall be charged a readiness to serve charge.

All mobile home parks shall be charged a readiness to serve charge based on the number of improved "pads" within the park regardless of if the pad is occupied by a trailer. Operation and maintenance charges shall be determined by the number of trailers occupied and unoccupied within the park or by actual meter readings if available. Mobile home parks will be master metered, and all unit flows will be subtracted from the master meter. The park owner will be responsible for the remaining flows after the deduction.

5.03 DELINQUENT CHARGES.

A penalty of 10% of the total balance due shall be assessed to any late payment received after 25th of the month the original bill was due. An additional 10% penalty shall be compounded on the total balance due on the 25th of each month there after until the balance is paid in full.

Certification of Delinquent Payments:

Past due amounts, together with accrued penalties, shall be certified quarterly to the Defiance County Auditor, pursuant to Ohio Revised Code, in March and September, who shall place such delinquencies upon the real property tax duplicate for the property receiving water/sewer service. Such delinquencies shall be a lien upon the property from the date the delinquency is placed upon the real property tax duplicate and shall be collected in the same manner as other real estate taxes. Failure to pay delinquencies certified may result in a foreclosure of the property by the Defiance County Treasurer. This part shall be in addition to all other collection remedies provided by law including on actions in small claims court. The County shall provide notice of certification of delinquent amounts by notice set forth on the Customer's monthly billing statement.

5.04 MAILING BILLS.

Bills for sewer service charges will be mailed to the owner of the property. Failure to receive bills will not relieve anyone of the responsibility for prompt payment. It is the property owner's obligation to notify the County Director of Defiance County Wastewater Operations of any change of or error of address.

5.05 MONTHLY CHARGES.

Current bills and delinquent bills not certified to the County Auditor for sewer service charges are payable at the office of the Defiance County Wastewater Operations or at any location specified on the bills themselves.

5.06 BUILDING SEWER PERMIT FEE.

See Appendix C.

5.07 PLAN REVIEW AND INSPECTION FEE SCHEDULE

See Appendix C.

**SECTION 6.00
USE OF PUBLIC SEWERS**

| | | | |
|------|-----------------------------------|------|---------------------|
| 6.01 | Storm sewage discharge. | 6.09 | Vacant Property. |
| 6.02 | Interceptors. | 6.10 | New Laterals. |
| 6.03 | Interceptor maintenance by owner. | 6.11 | Service Laterals. |
| 6.04 | Storage of sewage prohibited. | 6.12 | Inspection Refusal. |
| 6.05 | Plugging abandoned connections. | 6.13 | Review Fees. |
| 6.06 | Penalty. | 6.14 | Inspection Fees |
| 6.07 | Access. | | |
| 6.08 | Property Sale. | | |

6.01 STORM SEWAGE DISCHARGE.

- (a) Storm sewage shall be discharged to such sewers as are specifically designated as storm sewers, or to an open ditch approved by the County Engineer.
- (b) The house sewer shall successfully meet the required test; and shall be inspected by the Director of Defiance County Wastewater Operations or his representative before being covered.
- (c) The connection of roof drains, foundation or other clean water connections to the sanitary sewer is specifically prohibited.

6.02 INTERCEPTORS.

- (a) Grease, oil, and sand interceptors shall be provided when, in the opinion of the Director and/or Commissioners they are necessary for the proper handling of liquid wastes containing grease in excessive amount, or any flammable wastes, sand, or other harmful ingredients; except that such interceptors shall not be required for private quarters or dwelling units.
- (b) All interceptors shall be of a type and capacity approved by the Director and shall be located as to be readily accessible for cleaning and inspection.
- (c) Grease and oil interceptors shall be constructed of impervious materials capable of withstanding abrupt and extreme changes or temperature. They shall be of substantial construction, watertight, and equipped with easily removable covers which when bolted in place shall be gas tight and watertight.

6.03 INTERCEPTOR MAINTENANCE BY OWNER.

Where installed, all grease, oil, and sand interceptors shall be maintained by the owner, at his expense, in continuous and efficient operation at all times while being used but no less than every 90 days.

6.04 STORAGE OF SEWAGE PROHIBITED.

No garbage, industrial waste, sanitary sewage, or storm sewage shall be piled, stored, or ponded in such a manner so as to constitute a public nuisance.

6.05 PLUGGING ABANDONED CONNECTIONS; INSPECTIONS.

All sanitary sewer connections shall be plugged at the main when they are abandoned at the Owner's expense and shall not be further used as a result of the razing of any structure.

The plugging of a sanitary sewer shall be the responsibility of the property owner and shall be inspected by the Director or an employee of the Director of Defiance County Wastewater Operations Department before being covered.

6.06 PENALTY.

(EDITOR'S NOTE: See Section 2.07 for penalties applicable to this chapter if no other penalty is provided).

6.07 ACCESS.

Any structure refusing to grant access to exterior or interior inspection of sump pumps, plumbing, root, or footer connections shall pay \$50 per month surcharge and increasing by an additional \$50 per month in the second year and each year thereafter until access is granted.

6.08 PROPERTY SALE.

All property that is a change of ownership shall have an internal lateral inspection by a certified plumber with verification of completed repairs. Inspection shall be completed prior to the sale.

6.09 VACANT PROPERTY.

Vacant property taps that will be in proposed drives will require relocation of the tap or drive to eliminate this potential.

6.10 NEW LATERALS.

All new laterals will require trace wire from the street connection to the home or structure.

6.11 SERVICE LATERALS.

Service laterals not inspected before backfill will be re-excavated at contractor / homeowner expense.

6.12 INSPECTION REFUSAL.

All property refusing an inspection will be fined \$25 per day penalty.

6.13 REVIEW FEES.

All residential / commercial / industrial development will require a review fee and must be paid before any review is completed and approved.

See Appendix C.

6.14 INSPECTION FEES.

All estimated inspection fees are required to be escrowed prior to starting construction.

**SECTION 7.00
INDUSTRIAL / COMMERCIAL USERS
WASTEWATER PRETREATMENT STANDARDS**

Pretreatment, if required by the Director, shall comply with the standards for the wastewater treatment plant receiving the wastewater and OEPA / USEPA Standard.

All Industrial / Commercial users who are connected to the Defiance County Express Sewer, a sewer system including Lake Christi Meadows Subdivision, Brunersburg Sewer System, Breckler Road Sewer and SR 66 N Sewer, shall comply with the following sections of the City of Defiance Sewer Ordinance Section 925 and shall be responsible for coordinating with the City of Defiance:

| | |
|---------|---|
| 925.01 | Scope: Objection Paragraph B, Section 1, 2, and 3 |
| 925.05 | Limitation on Discharge to Public Sewer |
| 925.06 | Industrial User Discharge Permits, Reporting |
| 925.07 | Notification Requirements for Industrial Users |
| 925.08 | General Requirements for Industrial Users |
| 925.09 | General Conditions for Industrial Users |
| 925.13 | Enforcement |
| 925.135 | Appeals |
| 925.15 | Right of Entry |
| 925.23 | Notices of Violations |
| 925.24 | Damaging or Tampering with Wastewater Works |
| 925.25 | Severability |
| 925.26 | Conflicts |
| 925.99 | Penalty |

APPENDIX A

Procedures and Requirements:
Tap Connections

APPENDIX A
Procedures and Requirements:
Tap Connection to an Approved Sanitary Sewer System
Defiance County, Ohio

For connections to an approved sanitary sewer, it is necessary to perform the following:

1. Contact the Defiance County Wastewater Operation's Office at (419) 782-2230 to determine the availability of sewer. This includes a determination of the need for a grinder pump station. (This is determined by the type of sewer available.) Owner must provide an address and location map.
2. Obtain a permit to connect from the Defiance County Wastewater Operation's Office and pay all associated fees (this can be done by the property owner(s) or contractor.) See Appendix C for fees.
3. Additional permits may be required from the County Engineer's Office or the Ohio Department of Transportation if the sewer main is located in road right-of-way or is located on the opposite side of the roadway. This determination will be made by the Defiance County Wastewater Operation's Office.
4. The building sewer on the property shall be done by the owner or approved contractor according to County Regulations. The Contractor shall be licensed, bonded and carry the necessary insurance required by Defiance County.
5. Call the County Wastewater Operation's Office at (419) 782-2230 for inspection of all work performed before backfilling is completed. Monday thru Friday, between the hours of 9:00 a.m. and 3:00 p.m.
6. If a septic tank exists on the property, it shall be properly abandoned as directed by the Defiance County Health Department.
7. Plumbing waste lines and other drain lines within and outside the dwelling or public building shall be inspected for compliance with the following: roof down spout drains, footer drains, sump pumps discharging footer drain water, cistern over flow drains, and surface and sub-surface drainage lines are not allowed to be connected to the building sanitary drain or building sewer. Only water used within the building shall be discharged to the sanitary sewer. **NO INDUSTRIAL OR HAZARDOUS WASTE MATERIALS ARE ALLOWED IN THE SANITARY SEWER SYSTEM AT ANYTIME.**
8. The building sewer for a one (1), two (2), or three (3) family dwelling shall be at least six inches (6") inches nominal inside diameter. The building sewer for all commercial, industrial, or public buildings shall be at least six inches (6") nominal inside diameter. The minimum slope shall be 1/8" per foot. The building sewer shall be connected to the building drain by using a flexible neoprene coupling with stainless steel clamps or a solid watertight connector.

9. A building sewer shall be laid in undisturbed earth using premium joint pipe as listed below. Six-inch (6") "Clean-outs" with six-inch (6") risers shall be installed as follows:
 - a. One (1) within five feet (5') from your building.
 - b. One (1) every one hundred (100) feet of length to the sanitary sewer, or at any change in direction greater than 45°.
 - c. Types of acceptable pipe which can be used for laterals:
 1. Polyvinyl Chloride (PVC) meeting (ASTM-D-3034 SDR 35).
 2. All building sewers shall be backfilled with #57 stone or equal to six inches (6") above the top of the pipe and four inches (4") below and six inches (6") on each side. The backfill with #57 stone shall extend to the bottom of any driveways and sidewalks.
 3. No glued fittings permitted.
10. The home or business owner including businesses with existing grinders will be responsible for installation, ownership and maintenance of all new grinder pumps. These shall have hour meters and the County shall have unrestricted 24-hour access. Sizing shall be by a certified plumber or professional engineer. All existing grinders that serve existing homes will become the maintenance responsibility of the new owner upon the sale of the property. The grinder must remain on the owner's property. This does not pertain to property owners who have signed the consent form and are subject to the consent form as of October 9, 2020. Any residential customer who did not sign the consent form as of October 9, 2020, will not be allowed to sign the form.
11. If there is a sanitary sewer manhole on the property or street right-of-way, it shall not be covered for any reason. Should you desire to raise the elevation of the ground, you must notify this office so that arrangements can be made to raise the opening. Should you fail to notify this office and cover the manhole, this office may take one of several actions:
 - a. Remove the fill over the manhole.
 - b. Raise the manhole and charge the contractor or the owner for any expense involved.
12. The sanitary sewer shall be placed so that a minimum horizontal distance of ten feet (10') and a minimum vertical clearance of eighteen inches (18") is maintained from any existing waterline.
13. **When calling for tap inspection from the County's Representative, please call at least 24 hours in advance, and have the job site prepared for inspection prior to our arrival. There will be an added fee for reinspection and there will be no weekend or holiday inspections. Defiance County Wastewater Operation's Office (419) 782-2230. Monday thru Friday, between the hours of 9:00 a.m. and 3:00 p.m.**

APPENDIX B

Procedures in the Construction of Sanitary Sewage Improvement

APPENDIX B
PROCEDURES IN THE CONSTRUCTION OF
SANITARY SEWAGE IMPROVEMENT
Defiance County, Ohio

SECTION 1. - Assessment Sanitary Sewerage Projects.

The following is a summary of procedures for construction of assessment and non-assessment projects and temporary subdivision systems.

1. A Resolution by the Board of County Commissioners establishing a sewer district.
2. Preparation of a general plan of sanitary sewerage for the sewer district and approval of same by the Board of County Commissioners and Ohio Environmental Protection Agency.
3. Receipt by the Board of County Commissioners of a petition from affected property owners, request of Township Trustees or Municipal officials and/or order of Defiance County Department of Health and/or OEPA for a sanitary sewerage improvement.
4. Preparation of detailed plans, specifications, estimates of cost, and tentative assessments for each improvement by the County Director of the Defiance County Wastewater Operations.
5. Approval of the detailed plans, specifications, estimates of cost, and tentative assessments by the Board of County Commissioners, by the municipality (if within one), Defiance County Health Department, and OEPA.
6. Passage and publication of a resolution of necessity by the Board of County Commissioners and notification of each property owner affected by the project and clerk of council of the municipality (if the project is within one) of the public hearing.
7. Holding by the Board of County Commissioners of a public hearing for all property owners who will be assessed or affected by the proposed improvement. The hearing will request any endorsements or objections to the proposed improvement. The Board of County Commissioners will receive letters of written comments for five days after the hearing from such property owners who desire to submit endorsements or objections to the proposed improvement.
8. Passage of a resolution determining to improve and proceed with the improvement by the Board of County Commissioners not sooner than five days after the public hearing.
9. Resolution to advertise for construction bids in a newspaper of general circulation in the County not sooner than ten (10) days after passage of a resolution to proceed.
10. Receipt of construction bids by Board of County Commissioners and tabulation of such bids by County Director of Defiance County Wastewater Operations.
11. Issuance of notes to finance the improvement by the Board of County Commissioners.

12. Award of the construction contract by the Board of County Commissioners to the lowest and best bidder.
13. Construction of the project.
14. Computation of the final cost of the project and revision of the tentative assessments in the same ratio as the final cost is to the Engineer's estimated cost. (In no case can the final costs or assessments exceed the estimated costs or tentative assessments at the time of the public hearing by more than 15%.)
15. Informing each property owner, he may pay his assessment without interest in cash during a 30-day period following the Board of County Commissioners approval of said assessments. A notice will be mailed to each property owner immediately after the Board's approval of said assessment and state the amount of his final assessment.
16. Issuance of bonds and redemption of notes by the Board of County Commissioners.
17. Computation of final unpaid assessments including bond interest and certification of same to the Board of County Commissions by the County Auditor.
18. Approval of final unpaid assessments as certified by the County Director of Defiance County Wastewater Operations including bond interest by the Board of County Commissioners and certification to the County Auditor for placing on the tax duplicate for collection for the number of years which equals the County debt schedule.

SECTION 2. - Non assessment Sanitary Sewer Projects

1. Consultation by the developer or owner with the Director of Defiance County Wastewater Operation as to general requirements.
2. The developer or owner should furnish five copies of the detailed plans, specifications, and estimates of cost as prepared by a Professional Engineer licensed in the State of Ohio for the project.
3. Review and approval of all plans and specifications by the Director of Defiance County Wastewater Operations, municipality, or township trustees (if located within one), Board of County Commissioners, OEPA, and County Health Department (if a sanitary sewerage improvement). Plans for facilities in residential subdivisions will not be approved by the Director until preliminary approval of the plans of said subdivision has been given by the appropriate Planning Commission.
4. At the same time of submission of the detailed plans and specifications to the County Director of Defiance County Wastewater Operations, the Owner's Engineer shall submit in triplicate detailed shop drawings as required by the County Director of Defiance County Wastewater Operations.
5. Submission of 100% Performance Bond or other satisfactory guarantee and necessary easements by the developer or owner to the County when plans are submitted.

6. Submission of two sets of "as-built" drawings to the County Director of Defiance County Wastewater Operations by the Owner's Engineer prior to acceptance of the project by the Board of County Commissioners. Copies of all daily observation reports shall be on file with the Commissioners or Director of Defiance County Wastewater Operations.
7. Acceptance of the project by the Board of County Commissioners for operation by the Defiance County Wastewater Operations.

SECTION 3. - Residential Subdivision Temporary Sanitary Sewerage

1. Consultation between the developer, the OEPA, and the County Director of Defiance County Wastewater Operations as to the possible methods of sewage disposal for the proposed subdivision.
2. If a temporary wastewater treatment plant is to be constructed, the developer shall obtain the services of a Professional Engineer experienced in wastewater plant design and licensed to practice in the State of Ohio.
3. The developer and his engineer shall submit, in quadruplicate, for the use and/or approval to the Ohio Environmental Protection Agency, County Health Department, the Director of Defiance County Wastewater Operations, and the Municipal Engineer (if within a municipality), a preliminary plan of wastewater disposal for the proposed subdivision.
4. The proposed plant site shall be examined by the developer and his engineer, the OEPA, the County Health Department, the Director of Defiance County Wastewater Operations, and the Municipal Engineer (if within a municipality) to ascertain the site's suitability. Any review fees shall be paid in advance.
5. The developer shall obtain written permission to discharge the plant effluent into a drainage course or storm sewer from the OEPA and any authority concerned with the maintenance of said drainage course or storm sewer prior to the submission of the detailed plans and specifications.
6. The developer shall enter into an agreement with the Board of County Commissioners which shall delineate the design, construction, and operation of the proposed wastewater treatment plant as approved by the Director of Defiance County Wastewater Operations.
7. Prior to the approval of the detailed plans and specifications, the developer shall submit all necessary deeds, easements, bonds, and deposits as stated in the Agreement with the Board of County Commissioners.
8. The developer and his engineer shall submit five satisfactory copies of the detailed plans, specifications, and estimates of cost for approval to the municipality (if located within one) or township trustees, the County Health Department, the Director of Defiance County Wastewater Operations, and the OEPA.
9. NO CONSTRUCTION IS TO COMMENCE UNTIL THE DETAILED PLANS, AND SPECIFICATIONS ARE REVIEWD AND APPROVED.

Upon approval of the detailed plans, specifications, and shop drawings, construction may commence under the continuous daily inspection of the County Director of Defiance County Wastewater Operations. The developer shall obtain all approvals necessary for the construction contemplated prior to the start of construction and create the required escrow account for review and inspection cost prior to the start of construction based on developer construction schedules.

10. The wastewater disposal plant and sanitary sewers will be accepted for operation and maintenance only after construction is completed to the satisfaction of the OEPA, the County Health Department, and the County Director of Defiance County Wastewater Operations and when all necessary final documents are submitted and approved by the Board of County Commissioners, including one set of "as-built" drawings as prepared by the developer's engineer and payment of all engineering and inspection costs incurred by the Defiance County Wastewater Operations.
11. A sewer permit shall be obtained from the Defiance County Wastewater Operations for the connection of each house to the street sanitary sewer, upon the acceptance of the wastewater disposal plant and sanitary sewers by the Board of County Commissioners.

SECTION 4. – Approval of Plans

1. Plans for proposed sanitary sewerage improvements which are proposed for construction in Defiance County, Ohio, outside of any municipal corporation, inside of any municipality with the municipality's consent to the County's acting on behalf of the municipality, or within or connecting or proposed to connect to any County-operated sewer district or system, shall be prepared by a Professional Engineer licensed to practice in the State of Ohio, who is experienced in such work, and shall be submitted to the Director of Defiance County Wastewater Operations for approval. Said plans shall then be submitted to the Board of County Commissioners (hereinafter called the Commissioners), to the Ohio Environmental Protection Agency and to other agencies and authorities prior to the installation of the improvement. Plans for the following classes of improvements must be submitted for approval, whether proposed for construction within or without any County sewer district previously established by the Commissioners.
 - a. **Class A** - Proposed public sanitary sewerage including treatment plants, sanitary sewage systems, and any changes in existing structures or methods of treatment for unincorporated communities, or other lands outside of municipal corporations creating or connecting with any County system. A public sanitary sewerage system shall be constructed to mean a system serving three or more dwellings or buildings as described above, except for the sanitary sewerage which is constructed on public lands, in public highways, dedicated roadways, streets or alleys, or in easements which serve less than three dwellings or buildings as above described, but which may, in the opinion of the Director of Defiance County Wastewater Operations, be made to serve additional dwellings or buildings, existing or proposed, along its line, or which may be extended to serve additional dwellings or buildings.

- b. **Class B** - Proposed sanitary sewerage including treatment or supply facilities of industrial or commercial establishments which discharge their wastes into a sanitary sewerage system operated and maintained by the County of Defiance, Ohio, or which is under lease or franchise from said County.

For the purpose of these regulations, an industrial establishment shall be one engaged in the manufacture of a product, and a commercial establishment shall be one which is engaged in selling goods or services to either a public or private clientele.

- 2. Proposed sanitary sewerage improvements of the classifications described in Section 1 of this Part may be constructed in Defiance County (hereinafter called the County) outside of any municipal corporation or inside of any municipality which the municipality's consent to the County's acting on behalf of the municipality subject to the following regulations:
 - a. **With an established sewer district on undedicated thoroughfares or private rights-of-way.** If the improvement is proposed for construction on an undedicated thoroughfare or private right-of-way, and it is to be operated by the Commissioners, the Owner shall agree to dedicate the thoroughfare or furnish a right-of-way deed for the private right-of-way. The Collection system shall be operated and maintained by the developer. A sanitary flow meter shall be installed at the boundary of the development and be owned operated and maintained by the developer. Such improvements shall be designed by, and the construction of such improvements shall be under the general supervision of a Professional Engineer licensed in the State of Ohio, experienced in the design and construction of sanitary sewerage facilities.
 - b. **Within a sewer district on a dedicated thoroughfare.** If the improvement is proposed for construction within an established County sewer district, on a dedicated and accepted thoroughfare or right-of-way, the improvement shall be designed by and the construction of such improvements shall be under the supervision of a Professional Engineer, registered in the State of Ohio, and experienced in the design and construction of sanitary sewerage facilities, and constructed under the provisions of the Commissioners and County Sewer District Law (Section 6117.01 et. seq. of the Ohio Revised Code).
- 3. Five copies of satisfactory detailed plans and specifications and estimates of cost and three copies of the detailed shop drawings, catalog data, pump performance curves, etc., for all improvements provided for under Section 1 and 2 of this Part shall be submitted to the Director of Defiance County Wastewater Operations, and shall be accompanied by (1) a report prepared by the design engineer, giving all pertinent data regarding the project, and (2) a communication addressed to the Commissioners referring to the plans and specifications and requesting their approval of the same. Such a communication shall be signed by the Owner.
- 4. Any plans and specifications which are improperly prepared or accompanied by insufficient or inaccurate information may be rejected by the Director of Defiance County Wastewater Operations, whereupon, revised plans and specifications or more sufficient data shall be submitted, as required. Construction of the improvement will not be authorized until satisfactory engineering plans and data have been submitted to and approved by all of the approving authorities.

5. At the time of submission of the plans and specifications, there shall be deposited with the Director of Defiance County Wastewater Operations, an amount of money, as estimated by the Director of Defiance County Wastewater Operations, sufficient to cover the cost of examining such plans and the accompanying data, including any field investigations and inspections in connection therewith, including inspection of construction.
6. The submissions to and approval of plans and specification for sanitary sewerage improvements by the Commissioners will not relieve the Owner from requirements of the OEPA with reference to the approval of plans and specifications for certain improvements.
7. The authorization to construct any sanitary sewerage improvement shall be by letter issued to the Owner from the Director of Defiance County Wastewater Operations stating that permission to commence construction has been granted. Such a letter shall not be sent until the approvals of the Commissioners, and where necessary, Ohio Environmental Protection Agency have been secured.

SECTION 5 – General Construction, Design, And Specifications Requirements of Sanitary Sewerage Improvements.

1. No sanitary sewerage construction included under the classification of Section 4 shall be started until after the plans have been approved by the Director of Defiance County Wastewater Operations, the Commissioners, and where necessary, the Ohio Environmental Protection Agency, and authorization has been granted by the Director of Defiance County Wastewater Operations, as herein provided. The installation shall be in strict accordance with such approved detailed plans, specifications, and shop drawings, etc. Construction of sanitary sewerage facilities to be operated by the County shall not proceed until detailed shop drawings have been submitted in triplicate and approved by the Director.
2. If any change or modification is deemed necessary or desirable by the public officials, or persons, firm or corporation having charge of work, previous to or during the construction, such change or modification shall be incorporated in revised plans, which shall be submitted for approval in the same manner as required for original plans.
3. Before receiving a permit for any work requiring excavation in any street, highway, or road right-of-way the person desiring to make such excavation shall obtain from the proper authority, the required permit for such work, and shall agree to comply with all requirements of the authority issuing such "road opening permit". If no "road opening permit" is required by the authority having jurisdiction over a particular street or highway, a written statement to the effect must be obtained from the authority. At all times, all traffic and emergency vehicle access must be maintained with steel plates for one way access.
4. The material and workmanship must conform in all respects to the requirements of the specifications of the County Director of Defiance County Wastewater Operations, which specifications shall be considered as minimum specifications, and if built by contract, the contract shall contain this stipulation.
5. No construction work in connection with the improvement shall be done except in the presence of an inspector authorized by the Director of Defiance County Wastewater Operations. Forty-

eight (48) hours of notice of the intention to begin work shall be given to the Director of Defiance County Wastewater Operations to enable him to arrange to place one or more, if needed, inspectors on the work. The Director of Defiance County Wastewater Operations shall also act as resident engineer for the improvement, but in a secondary capacity.

6. If the Director of Defiance County Wastewater Operations has proof of evidence in writing that any such work is being improperly done, he may order all work stopped and the owner or his contractor shall thereupon stop and shall not resume until authorized in writing by the Director of Defiance County Wastewater Operations to do so.
7. Wye-branches, manholes, and other sanitary sewer appurtenances shall be placed where required by the Director of Defiance County Wastewater Operations.
8. Connections with sanitary sewers constructed under this Article shall be subject to all the requirements of these regulations.
9. At the completion of the work, a set of "as-built" plans shall be furnished by the owner's engineer showing the exact location and depth of all sanitary sewers, location of laterals, and appurtenances thereto along with any approved changes no later than 60 days after acceptance of construction.
10. No provision in this article shall be so constructed as to relieve the Owner from the responsibility to furnish all private engineering, surveying, and inspection services necessary in connection with the improvements.
11. The County expressly disclaims any responsibility for the accuracy or completeness of information given on drawings, orally or in writing, by any of its employees in regard to existing structures, and the contractor shall have no claim against the County on the account of such information given.
12. In excavating, backfilling trenches and constructing sanitary sewerage facilities care must be taken not to move or injure any structures whatever, and watercourses, whether above, at, or below the surface of the ground. If necessary, the contractor or the sewer builder in the case of house sanitary connections, shall, at his own expense, align, shore up, secure, and maintain in operating condition any such structure or watercourse. If damaged, he shall repair any such damage, and shall maintain them in good repair until the final acceptance of the job and for a period of time one year thereafter. The plans will include all erosion control details and the NOI permit.
13. Approval of the quality of all materials and workmanship by the Director shall be required. The Director may require testing of equipment or materials at the place of manufacture by an independent testing laboratory or by others, at no expense to the County.
14. General minimum specifications that apply to sanitary sewer lines, other than house connections, are as follows:
 1. All sanitary sewer pipe shall be of the premium rubber joint type, in accordance with the latest ASTM Designation.

2. The minimum size of any sanitary sewer mains, except local laterals, shall be eight (8) inches inside diameter.
3. The slope of the sanitary sewer main shall be determined so as to provide a minimum velocity of two (2) feet per second when the sewer is flowing half-full. The minimum slope per foot shall not be less than 0.0040 for eight (8) inch pipe, 0.0028 for ten (10) inch pipe, 0.0022 for twelve (12) inch pipe, and 0.0015 for fifteen (15) inch pipe using a Kutter's "n" value of 0.013.
4. After construction has been completed and the sewers cleaned, all sanitary sewer mains shall undergo an infiltration test and video inspection in accordance with the following:
 - (a) Where sewers are constructed below the ground water table, they shall be inspected for excessive leakage at all joints. In small diameter sewers, this may be done by lamping between manholes or by the use of a camera. In sewers large enough for entry of workmen, the joints shall be inspected from the inside of the pipe. Any joints that are leaking excessively or where water is jetting through shall be repaired. Sewers shall be uncovered, if ordered, and the faulty joints repaired from the outside.
 - (b) At times selected by the Director of Defiance County Wastewater Operations, after the sewers have been visually inspected and all observed leakage stopped, the infiltration into sanitary sewers shall be measured. The Contractor shall isolate sections of the sewer by the installation of bulkheads in the pipe as required and the measurement shall be made by means of a V-notch weir or other approved method.
 - (c) The test in each section shall be continued for at least 24 hours and, if its measured leakage during that period exceeds 200 gallons per inch of diameter per mile of pipe, the Contractor shall locate the point of infiltration and make necessary repairs, continuing the work until infiltration is reduced to the permissible maximum as specified. The length of section tested shall be determined by the Engineer and each section tested of any length shall be within the permissible maximum.
5. After the backfill has been in place for 30 days or more, the Contractor shall test by a method approved by the Director all PVC sewers to determine the pipe deflection. If available, electronic equipment shall be used to measure the deflection. If such equipment is not available, deflection tests can be run by the use of rigid balls or mandrels, having diameters equal to 95% of the inside diameter of the pipe, pulled through the sewer line. If rigid balls or mandrels are used, tests shall be performed without mechanical pulling devices. All sewer pipe exceeding the maximum allowable deflection shall be replaced at the Contractor's expense.
6. The minimum inside diameter of manholes shall be four (4) feet in accordance with the Defiance County Standard Manholes and shall be thoroughly waterproofed. Precast concrete manholes shall be constructed with precast adjusting rings between the manhole cover frame and the top precast concrete section. Manhole frames, covers, and steps shall be in accordance with Defiance County Standards. All manhole

connections shall be by a premium Manufactured approved Rubber Boot.

7. Manholes shall not be spaced greater than 400 feet on sewers to 24-inch (24") diameter and 500 feet on sewers greater than 24-inch (24") diameter.
8. The allowable pipe loading shall be computed by using the maximum trench width – usually the pipe outside diameter (O.D.) plus eighteen (18) inches or thirty inches (30"), whichever is greater – and an “ordinary bedding” condition.
9. All sanitary sewers shall be laid on a granular bedding, consisting of crushed stone (no crushed slag), meeting the requirements of ODOT Table 703-1, Size No. 8. The bedding shall extend from four inches (4") below the bottom of the pipe to six inches (6") above the top of the pipe.
15. All main sanitary sewers shall be extended along dedicated road right-of-way to the limits of the property being served by those utilities. It may be required that main sanitary sewers that are located within easements, also be extended to the limits of the property being served by those utilities.
16. Water mains and main sanitary sewers are to be constructed on opposite sides of traveled ways or pavements within easements, dedicated roads, and rights-of-way. In instances where this is a physical impossibility, a minimum of ten (10) feet shall be maintained between water mains and main sanitary sewers. The construction of sewers in easements at the rear or side of residential lots shall be prohibited except as approved by the Director of Defiance Wastewater Operations. Where sewers cross watermains, a minimum of eighteen inches (18") vertical clearance encased in concrete.

SECTION 6. – Construction Plans Format

- A. Standard Sheet: Class A 24" x 36".
- B. Lettering: All lettering .125" high or larger.
- C. Title Block: 6" x 3" located in lower right hand corner or 2" wide located along the right hand edge of the drawing sheet.
Include: Sewer district, plat name, section, engineer's name, seal, signature, sheet number, number of sheets and scale.
- D. Revisions Block: 4" x 3" located directly to left of corner title block or 2" x 3" located directly to the right of the edge style title block.
- E. Scale: Horizontal – 1"
- F. Signature Block (on cover sheet as shown at right): Places for (in order from top to bottom):
 - 1. Board of County Commissioners and Clerk (four spaces).
 - 2. County Sanitary Engineer.
 - 3. County Engineer when on or crossing a County road.
 - 4. Director of water and/or services for other political entities where applicable.
 - 5. The applicable City or Municipal Engineer when within corporation limits.
- G. A vicinity map shall be provided to show the location of the job.
- H. If there are five (5) or more sheets, a cover sheet is required containing the signature block and a key map with sheet reference numbers.
- I. Each sheet shall have a readily readable North arrow oriented up and/or to the left.
- J. Each set of plans shall contain this note in addition to other applicable General Notes: "All sanitary sewers and appurtenances shall be constructed according to Defiance County Wastewater Operations specifications".
- K. Profiles for both sewer and water shall be shown on the same sheet as the plan. The profile shall be below the plan and shall be taken at the pipe centerline or the road centerline if noted. The profile shall be lined up under corresponding points on the plan. The existing and proposed grade profile shall be shown on each profile view. Sanitary sewer profiles shall be split only at manholes; however, if it is absolutely necessary to end a drawing in the middle of a sanitary sewer span, a match line must be used and the lineal feet should relate to the length of span shown on that sheet. Water profiles are only required at points of crossing with other underground utilities and at those locations where the water line is greater or less than four feet six inches (4' 6") deep.
- L. All existing structures in the street or easement shall be shown in both plan and profile. Sizes, location, dimensions and elevations shall be included. These structures include but are not limited to:

1. Gas mains.
 2. Electric and telephone conduits.
 3. Storm sewers.
 4. Sanitary sewer lines.
 5. Water lines.
 6. Telephone poles.
 7. Street lights.
 8. All above ground structures which may affect construction.
- M. Manholes shall be consecutively numbered from lowest to highest elevation and station numbers shall be noted. Manhole #1 shall be assigned Station No. 0 + 00 and shall be the manhole connected to the existing system. Both manhole and station numbers shall appear on both plan and profile. There shall be no duplication of manhole numbers within a particular development.
- N. The length, grade and size of reach span of sewer shall appear on the profile.
- O. The type of pipe material, joints and strength shall be shown in the profile for both sewer and water, using the ASTM nomenclature.
- P. The location of all special features such as concrete encasements, siphons, elevated sewers and special cross sections shall be shown.
- Q. Details of all special appurtenances such as manholes, inspection chambers, siphons, regulators, metering devices, elevated sewers, etc., shall be shown.
- R. All subdivision and Plat Book page shall be clearly marked including lot numbers. All properties abutting the improvement shall be shown for full width and depth.
- S. The ownership, including Deed book, page and acreage, of all property not subdivided by a record plat shall be shown on the preliminary plans and cover sheet.
- T. All corporation lines with dimensions and other information that will fix the exact location shall be shown on the preliminary plan and cover sheet and be geo referenced to Ohio State Plane Coordinates (NAD83 Zone 3402). Section, Township, Range and USGS Index Number shall be included.
- U. Private driveways, lanes, and easements with appropriate dimensions shall be shown by dashed lines. All sanitary sewer easements shall be a minimum of 20' in width.
- V. The location, description and elevation of all benchmarks used in connection with the project shall appear on each appropriate sheet.
- W. Test borings shall be located when made.
- X. Proposed lines shall be shown as solid dark lines. Existing lines shall be shown as dashed lines.
- Y. Existing or proposed streets and all streams or water surfaces shall be clearly shown. Contour lines at appropriate intervals shall be shown.

SECTION 7. – Construction Plans - Specifications

Complete technical specifications for any special construction shall be submitted to the Director. No construction shall begin before these specifications have been approved.

SECTION 8. – Construction Plans – Revisions to Approved Plans

Any deviation from approved sanitary sewer or water plans and specifications shall be submitted to and have received approval of the Director before such changes are made “As-built” plans clearly showing such changes shall be submitted at the completion of the work.

SECTION 9. – Construction Plans – Approval Period

Approved plans are only good for one hundred twenty (120) days, after which time they must be re-submitted for re-approval unless construction has begun.

SECTION 10. – Construction Plans – “As-Built” Drawings

- A. “As-built” drawings must not have any objects, dimensions, elevations, grades, etc., crossed out. They must be erased from the drawing.
- B. All sanitary manholes and water valves must be located with a minimum of two (2) dimensions required on all locations in addition to state Plane coordinates.
- C. Plugged ends of sanitary sewer and waterlines with no service lines must be located.
- D. All “as-built” witness dimensions are to be measured in feet and tenths of a foot and are not to exceed one hundred feet (100’) in length. Dimension lines shall be shown on drawings except where they would add substantial confusion in interpretation. Written dimensions with an arrow pointing to the valve or sanitary manhole being referred to will then be acceptable. Dimensions shall be from centerline to centerline except for house corners and catch basins. Written dimensions will be considered at right angles with one another unless noted or shown otherwise.
- E. Measurements shall be on the horizontal.
- F. Abbreviations will be accepted for the following:

| | | |
|----|------------------------|-------------|
| 1. | Sanitary Manholes..... | San. M.H. |
| 2. | Catch Basins..... | C.B. |
| 3. | Curb..... | C |
| 4. | Fire Hydrant..... | F. Hyd. |
| 5. | Directions..... | N. S. E. W. |
| 6. | Property Line..... | PL |
| 7. | Center Line..... | CL |
| 8. | Water Main..... | Wtr. Mn. |

G. The following will be required on all "as-built" drawings:

1. Distances between sanitary manholes and between a sanitary manhole and the plugged end of the line are to be shown on the plan.
2. Length of span, grade, size of pipe, type, and invert elevations will be required on the profile:
 - a) Length of span may vary $\pm 1.0'$ before manhole location in profile must be changed. The elevation, however, must be marked clearly and correctly.
 - b) Invert elevations may vary $\pm 0.25''$ before main line in profile must be changed. The elevation, however, must be marked clearly and correctly.
3. Measurements between laterals and the nearest downstream manhole for sanitary sewer and the nearest downstream sanitary manhole for water except in special, approved circumstances where the nearest main line water valve or a fire hydrant may be used. Measurements for sanitary sewer laterals shall be from the end of the lateral, and not the tee location, and shall include depth and length.

H. The following is a list of objects that will be acceptable for "as-built" dimension references:

1. Fire Hydrant.
2. Curb (all curb dimensions must be perpendicular to the back of the curb and must not be to any curb or extended curb lines with a radius).
3. Catch Basin:
 - a) Dimensions are to be to the nearest corner of the steel edge on the street side.
 - b) The street and corner on which the catch basin is located must be indicated.
4. Sanitary Manholes.
5. Utility pole (when a dimension to a utility pole is used, the description and number of the pole must be given).
6. House Corner (when a dimension to a house corner is used, the address must be given).
7. Corner of a concrete drive (house number must be given).

SECTION 11. – Construction Plans – Procedure on "As-Built" Drawings

- A. "As-built" information and changes will be made in AutoCAD latest release or approved earlier format in construction drawing layout (no changes should be needed to open or plot drawings).
- B. Two (2) sets of "as-built" paper prints will be submitted to the Defiance County Wastewater Operation's Director for checking within (60) days of completion.
- C. The Engineer or Developer will be notified of acceptance or corrections by the Director.

APPENDIX C

Rates and Fees

APPENDIX C

RATES AND FEES

All connections to a Defiance County Wastewater System will be charged a minimum 1 user charge which includes a readiness to serve charge and a conveyance/treatment charge. (See Appendix E for current rates) or as follows:

Residential:

- Single family homes – 1 user charge.
 - Vacant lots with an existing sanitary sewer fronting the property will be charged a readiness to serve charge.
- Multi-Family - Apartment buildings, Duplex's, Tri-plex's, etc. - 1 user charge per apartment.

Mobile Home Parks: (*)

- A flow meter is required for all Mobile Home Parks. Each lot with a trailer will be charged 1 user charge. Each developed lot without a trailer will be charged a readiness to serve charge of \$7.10/month. Additionally, the Mobile Home Park will be charged for daily flows that exceed the user flow per trailer. (Allowable user flow is 150 gpd. /Trailer). The rate will be equivalent to the current City of Defiance rate of \$4.92 / 750 gallons. **(This rate will be adjusted annually).**

Commercial: (*)

- Retail or Office – 1 user charge per 8 employees or fraction thereof above the minimum.
- Food Services – 1 user charge per 5 seats or fraction thereof above the minimum.
- Car Wash (or similar type of business) – 2 user charges per automatic bay. 1 – User charge per manual bay, plus the current charge of \$4.92 per 750 gallons of discharge above the allowable user flow (150 gpd. / user). Flow meters are required.

Institutional: (*)

- Churches – 1 user charge, plus the current charge of \$4.92 per 750 gallons of discharge above the allowable user flow (150 gpd. / user). Flow meters are required.
- Schools – 1 user charge, plus the current charge of \$4.92 per 750 gallons of discharge above the allowable user flow (150 gpd. / user). Flow meters are required.
- Hospital/Hospice/Nursing Homes – 1 user charge, plus the current charge of \$4.92 per 750 gallons of discharge above the allowable user flow (150 gpd. / user). Flow meters are required.

Industrial: (*)

- Facility that does not use water for processing. – 1 user charge per 6 employees.
- Facility that uses water for processing and discharges water to the sanitary system. – 1 user charge per 6 employees, plus \$4.92 per 750 gallons for flows exceeding the user charge flow rate. Flow meter required. **(This rate will be adjusted annually).**

(*) Note: The standard daily flow for a single user charge (or Equivalent Dwelling Unit) is 150 gpd.

| Other Fees: | Permit | * Connection |
|---------------------------------------|---------------|---------------------|
| Residential | \$50.00 | \$3,000.00 |
| Commercial / Institution / Industrial | \$100.00 | \$4,000.00 |

(*) This fee includes a one-time inspection if the tap connection. If additional inspections are required, they will be billed at \$100.00/per inspection.

Plan Reviews and Inspections:

(Required for Mobile Home Parks, Subdivisions, Commercial and Industrial Projects).

Fee shall be required to defray the expenses associated with review of plans (including the need to retain a registered professional engineer by the County) to advise the County of the suitability of plans and inspection of improvements.

- Pre-application / Concept Plan Review \$200.00
- Detailed Construction Plan Review \$200.00 plus, current hourly rate of consultant
- Inspection Current hourly rate of consultant

APPENDIX D

Flow Meters

APPENDIX D

Flow Meters

All mobile home parks, and private residential developments with no public roads, car washes, restaurants / food service and commercial, industrial facilities that utilize water as part of their business (process or otherwise), or any facility which utilizes a private pump station or multi-use grinder pump must install a sanitary flow meter.

The flow meter must be installed in a manhole (for gravity flow) or separate meter pit structure for force mains.

1. Submit plans and specification (in triplicate) of the meter installation. Location of meter and controls must be approved by the Defiance County Wastewater Operations. Review of submittals will be completed within 30 days.
2. After approval and installation of meter, contact the Defiance County Wastewater Operations at (419) 782-2230 to schedule an inspection of the installation. Monday thru Friday, between the hours of 9:00 a.m. and 3:00 p.m. The owner/developer has 6 months from the date on the letter for installation and calibration of the flow meter.
3. Provide a certification for the meter installation that the meter has been calibrated after installation.
4. Final approval of installation will occur within 30 days of receiving the certified calibration report. The hour meters shall be used until the day of approval. Final readings of the hour meter shall be taken within 2 days of final approval.

Until the flow meter installation is complete, billings will be based on hour run time for grinder pumps and EDU counts for gravity lines.

The meter must be re-calibrated and certified on an annual basis at the owner's expense. All results shall be submitted to Defiance County.

If the flow meter has not been recalibrated on the annual basis or if malfunctions in anyway, the owner will be billed at the highest flow rate recorded in the previous 12 months until such time as repairs/recalibration has been corrected.

APPENDIX E
Resolutions
Resolution approving Regulations
Resolution setting rates

BOARD OF DEFIANCE COUNTY COMMISSIONERS

RESOLUTION: IN THE MATTER OF: APPROVE DEFIANCE COUNTY SANITARY SEWER USE REGULATIONS

DATE: THURSDAY, DECEMBER 23, 2021

The Board of Commissioners, County of Defiance, State of Ohio met in regular session on the above date in the Defiance County Commissioners' Conference Room with the following members present:

Mick Pocratsky: PRESENT Ryan Mack: PRESENT David S. Kern: PRESENT

Commissioner KERN moved and Commissioner MACK seconded the adoption of the following Resolution:

WHEREAS, Chapter 6117 of the Ohio Revised Code provides that the Board of Commissioners may make, publish, and enforce rules and regulations for the construction, maintenance, protection, and use of sewers and sewer improvements in its respective county; and

WHEREAS, Poggemeyer Design Group, A Kleinfelder Company, submitted revised Defiance County Sanitary Sewer Use Regulations, which were recommended to be adopted by the Defiance County Wastewater Operations' Director.

THEREFORE, BE IT RESOLVED, that the Defiance County Board of County Commissioners does hereby approve the Defiance County Sanitary Sewer Use Regulations, effective December 23, 2021, which will supersede any other sanitary sewer use regulations of the County.

BE IT FURTHER RESOLVED, that it is found and determined that all formal actions of this Board concerning and relating to the adoption of this Resolution were so adopted in an open meeting of this Board and that all deliberations of this Board and of any of its committees that resulted in such formal action were in meetings open to the public in compliance with all legal requirements, including Section 121.22 of the Ohio Revised Code.

The roll call vote upon its adoption resulted as follows:

MICK POCRATSKY

Mick Pocratsky yes

RYAN MACK

Ryan Mack yes

DAVID S. KERN

David S. Kern yes

MOTION CARRIED:

ATTEST: *Stephanie M. Metz*, CLERK

STEPHANIE M. METZ

BOARD OF DEFIANCE COUNTY COMMISSIONERS

RESOLUTION: IN THE MATTER OF: APPROVE DEFIANCE COUNTY SANITARY SEWER RATES

DATE: THURSDAY, DECEMBER 23, 2021

The Board of Commissioners, County of Defiance, State of Ohio met in regular session on the above date in the Defiance County Commissioners' Conference Room with the following members present:

Mick Pocratsky: PRESENT Ryan Mack: PRESENT David S. Kern: PRESENT

Commissioner KERN moved and Commissioner MACK seconded the adoption of the following Resolution:

WHEREAS, Chapter 6117 of the Ohio Revised Code provides that the Board of Commissioners shall fix reasonable rates for the use, or the availability of use, of the sanitary facilities of a sewer district; and

WHEREAS, Ohio Rural Community Assistant Program completed a sewer rate analysis for all of the County's sewer systems and provided recommended rates for the Defiance County Wastewater Operations to meet all financial obligations as well as the recommendation to create uniform charges for all of the County's sewer districts; and

THEREFORE, BE IT RESOLVED, that the Defiance County Board of County Commissioners does hereby approve the following sewer rates in accordance with the newly adopted Defiance County Sanitary Sewer Use Regulations, effective for sanitary usage beginning February 1, 2022 (billed in March 2022):

- \$68.75 per EDU;
- \$35.20 per vacant lot;
- \$7.10 per vacant within mobile home parks.

BE IT FURTHER RESOLVED, that it is found and determined that all formal actions of this Board concerning and relating to the adoption of this Resolution were so adopted in an open meeting of this Board and that all deliberations of this Board and of any of its committees that resulted in such formal action were in meetings open to the public in compliance with all legal requirements, including Section 121.22 of the Ohio Revised Code.

The roll call vote upon its adoption resulted as follows:

| | | |
|----------------|------------------------------|------------|
| MICK POCRATSKY | <u><i>Mick Pocratsky</i></u> | <u>YES</u> |
| RYAN MACK | <u><i>Ryan Mack</i></u> | <u>YES</u> |
| DAVID S. KERN | <u><i>DK</i></u> | <u>YES</u> |

MOTION CARRIED:

ATTEST: *Stephanie M Metz*, CLERK
STEPHANIE M. METZ

APPENDIX F

Details / Sanitary Sewer Connection Request Form

Business Phone

Cell Phone

Email Address

Address

City

State

Zip Code

Owner's / Representative Signature

Date

Board of County Commissioners

Date

Board of County Commissioners

Date

Board of County Commissioners

Date

Poggemeyer Design Group, County Consultant

Date

Wastewater Director

Date

- NOTE :**
1. ALL BACKFILL AND BEDDING MATERIAL SHALL BE PLACED IN MAX. 6" LAYERS AND COMPACTED BEFORE NEXT LAYER IS PLACED.
 2. BEYOND THE HATCH LIMITS SHOWN ON THESE DETAILS, NATIVE BACKFILL APPROVED BY THE ENGINEER MAY BE USED.

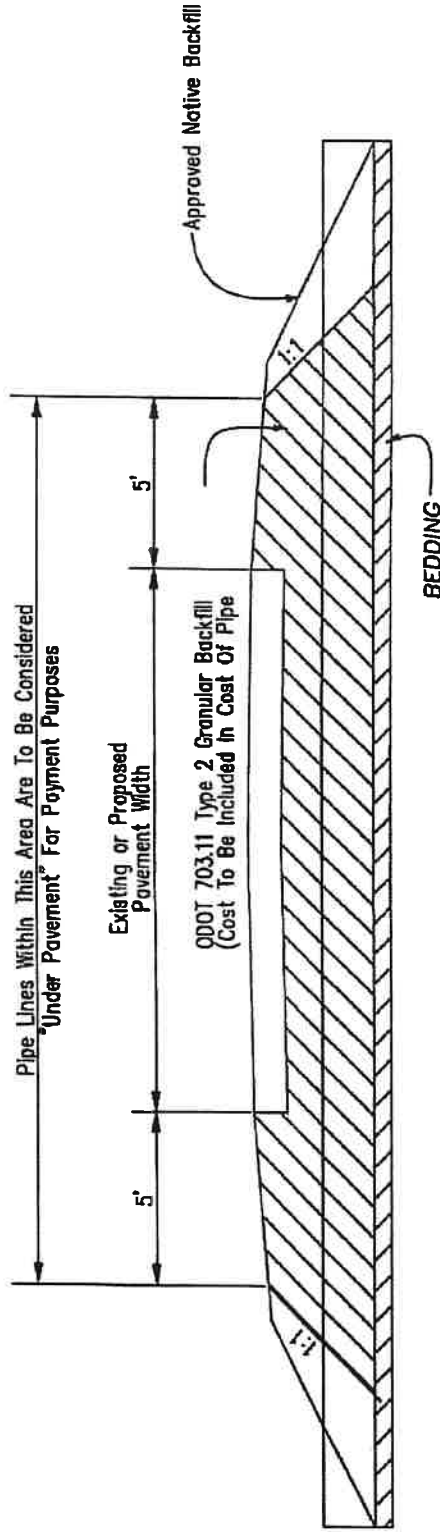
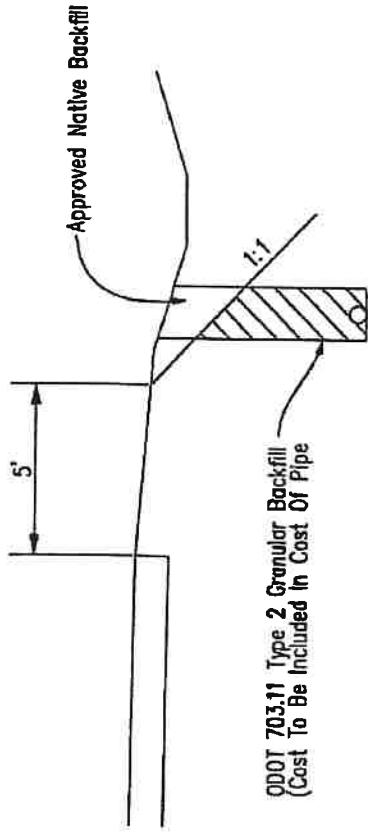

GRANULAR BACKFILL LIMITS DETAILS

Not to Scale



**POGEMEYER
DESIGN GROUP**

A KLEINFELDER COMPANY

101 CLINTON ST., SUITE 1300
DEFIANCE, OH 43512
PH: (419) 782-3067

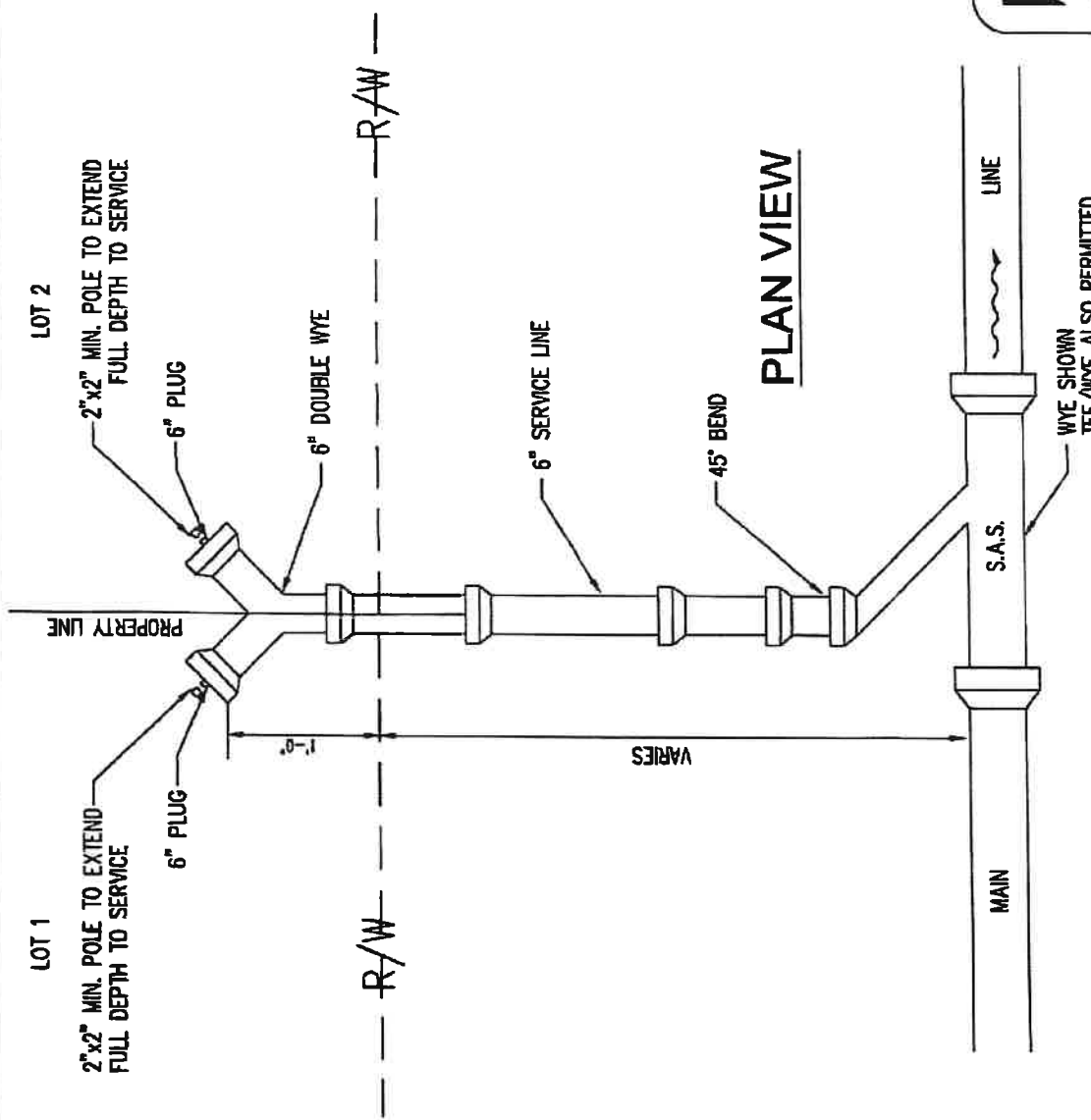

**POGEMEYER
DESIGN GROUP**
A KLEINFELDER COMPANY
101 CLINTON ST., SUITE 1300
DEFIANCE, OH 43512
PH: (419) 782-3067

TYPICAL DOUBLE SERVICE CONNECTION

Not to Scale

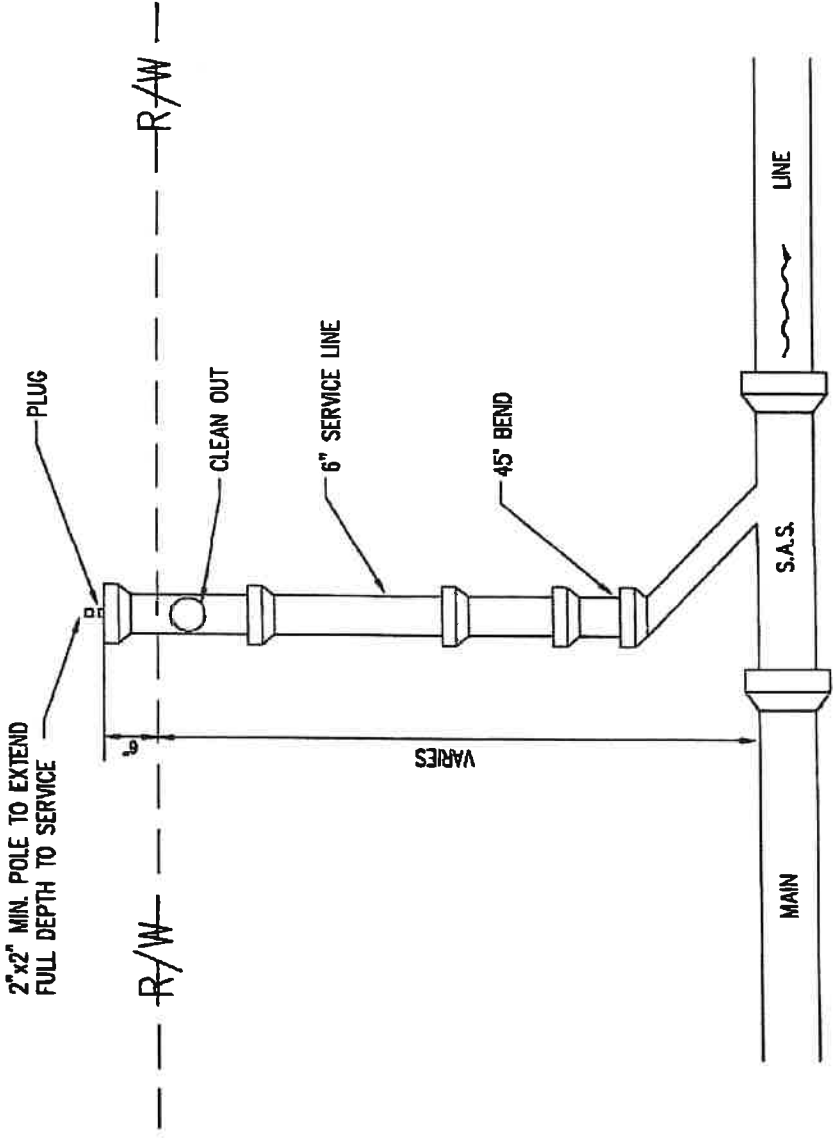

2"x2" MIN. POLE TO EXTEND
FULL DEPTH TO SERVICE

--- R/W ---

6'

VARIES

MAIN LINE

S.A.S.

45' BEND

6" SERVICE LINE

CLEAN OUT

PLUG

TYPICAL SERVICE CONNECTION

Not to Scale



**POGGEMEYER
DESIGN GROUP**

A KLEINFELDER COMPANY
101 CLINTON ST., SUITE 1300
DEFIANCE, OH 43512
PH: (419) 782-3067

SEWER CONNECTION

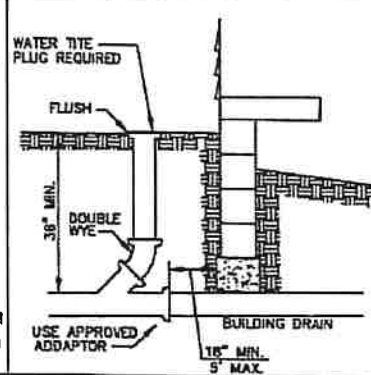
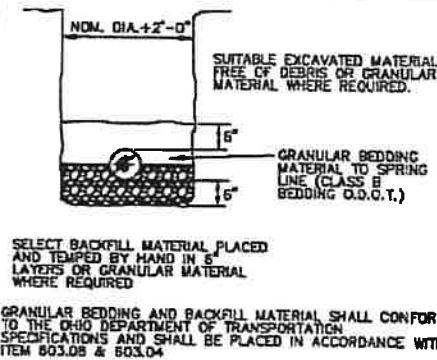
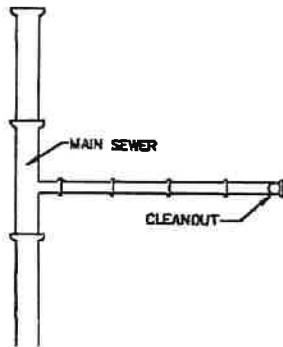
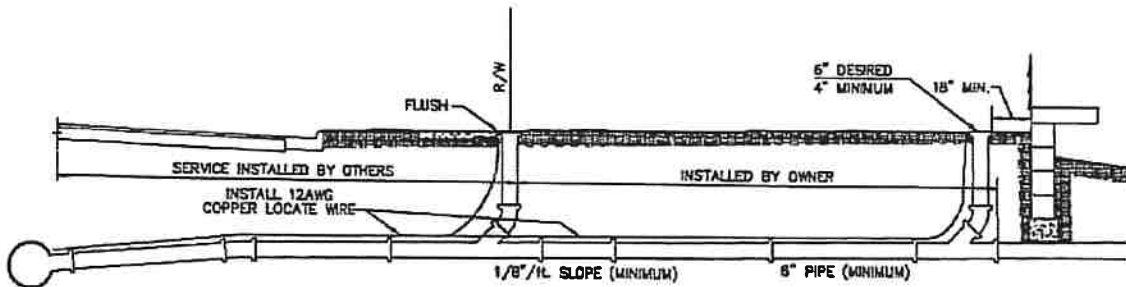

Sanitary Sewer Connection and Tap Standards and Specifications

1. Sewer tap shall be made of the same material as the main sewer to minimize infiltration from the connection between the main sewer and building lateral. All pipes shall be PVC (SDR-35) and conform to ASTM 3034. When joint dimensions are not compatible, a commercial adaptor shall be provided.
2. The sewer connection pipe shall be a minimum of 6-inch in diameter.
3. Roof drains, foundation drains and all other clean water connections to the sanitary sewer are prohibited.
4. There shall be no physical connection between a public or private potable water system and a sewer, or appurtenance thereto, which would permit the passage of any sewage or polluted water into the potable supply.
5. Sanitary sewer shall be a minimum of 50 feet from any water supply source (i.e. wells).
6. Sewer cleanout with a removable waterproof cap at the top of the cleanout shall be required and placed about 5 feet from the edge of the building and @ 100' intervals. Refer to the attached details for construction standards. Whenever a cleanout is installed in a driveway, road or sidewalk, a heavy-duty removable waterproof gray iron casting solid lid shall be placed at the top of the cleanout. This lid shall be Neenah Foundry Company R-1975 or approved equal.
7. Sewer pipe shall be laid on and covered with at least 6-inch of granular material (i.e. 8's or 57's stone). Stog is not permitted. There should be a minimum of 36-inch cover over pipe. Trench backfill shall be of a suitable material removed from the excavation. Debris, frozen material, large clods or stones, organic matter, or other unstable materials shall not be used for backfill within 2 feet of the top of the pipe. Backfill shall be placed in such a manner as not to disturb the alignment of the pipe.
8. Straight lines, proper fittings and provisions for cleaning shall be used to insure proper flow and trouble-free use. Where bends greater than 45° are used, cleanouts shall be installed. Where bends of 45° or less are used, a minimum of one 3-foot straight section of pipe shall separate the bends.
9. The Owner is responsible for notifying all underground utilities of excavating when digging in the service line. All utilities may be notified by calling the Ohio Utilities Protection Service (OUPS) at 1-800-302-2764.
10. Contact the County Health Department for procedures to abandon existing septic tank.



**POGGEMEYER
DESIGN GROUP**

A KLEINFELDER COMPANY

101 CLINTON ST., SUITE 1300
DEFIANCE, OH 43512
PH: (419) 782-3067

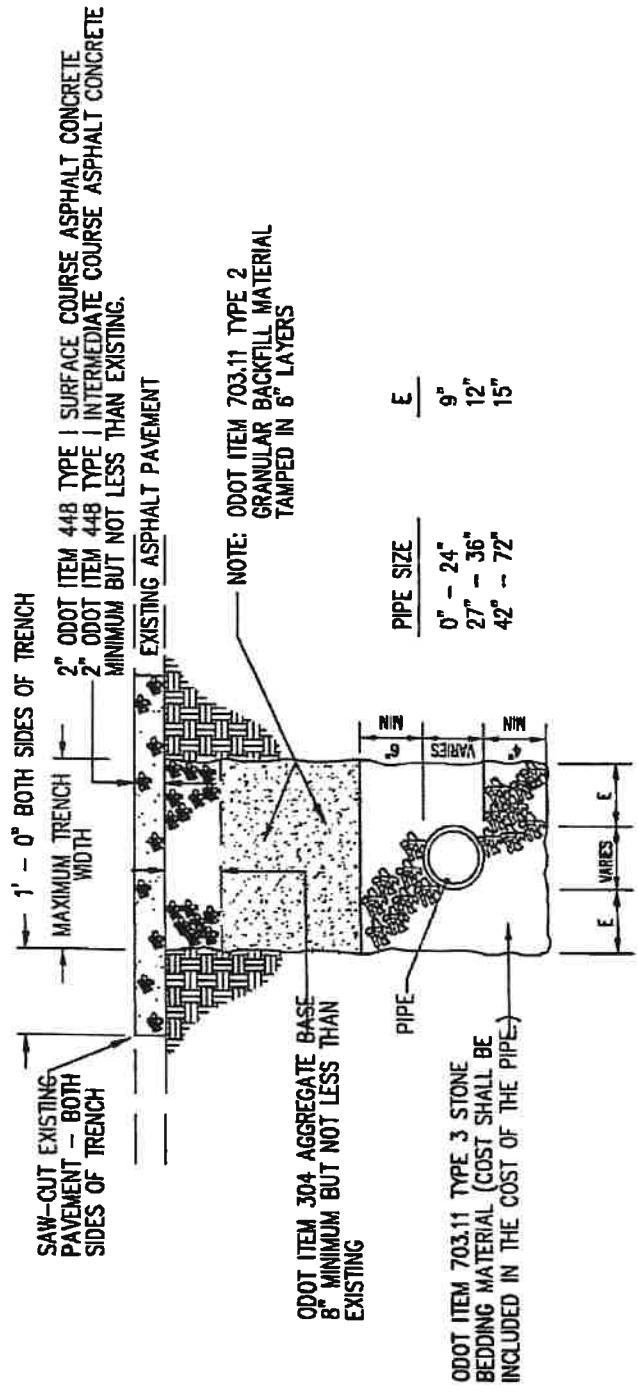

| PIPE SIZE | E |
|-----------|-----|
| 0" - 24" | 9" |
| 27" - 36" | 12" |
| 42" - 72" | 15" |

TRENCH DETAIL IN ASPHALT PAVEMENT

TYPE I
Not to Scale



**POGEMEYER
DESIGN GROUP**
A KLEINFELDER COMPANY
101 CLINTON ST., SUITE 1300
DEFIANCE, OH 43512
PH: (419) 782-3067

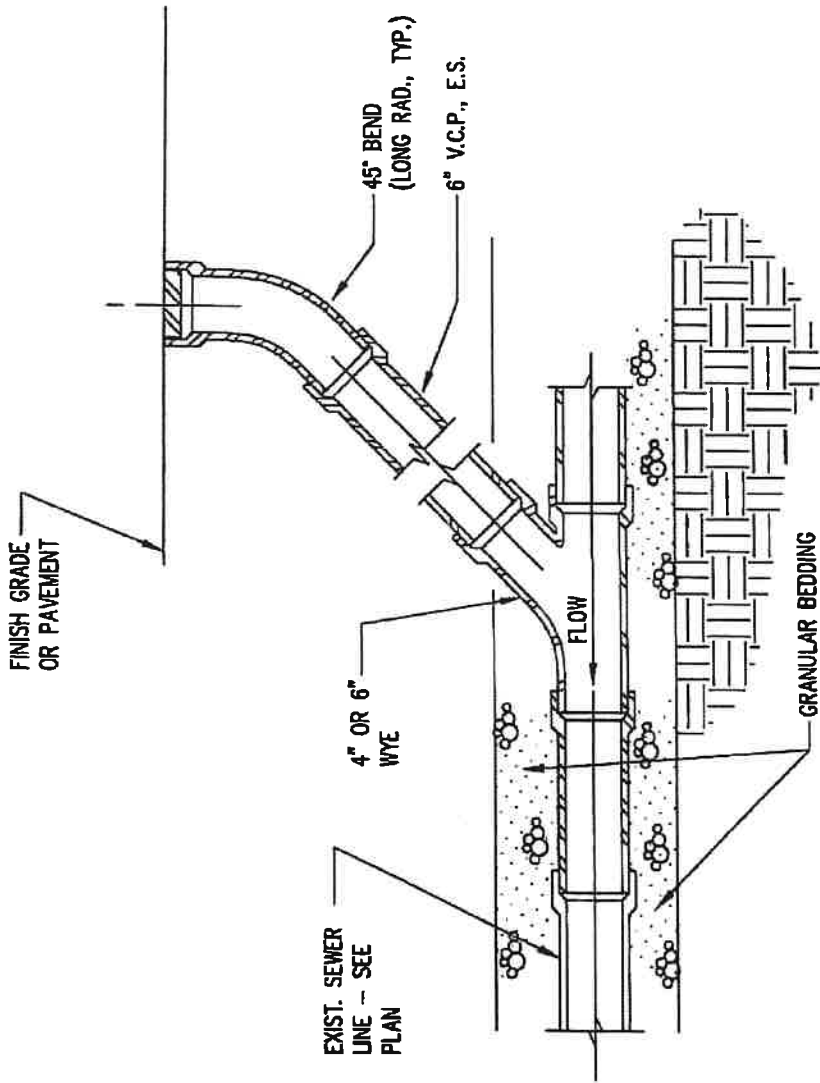

CLEAN-OUT DETAIL

Not to Scale



**POGEMEYER
DESIGN GROUP**

A KLEINFELDER COMPANY
 101 CLINTON ST., SUITE 1300
 DEFIANCE, OH 43512
 PH: (419) 782-3067

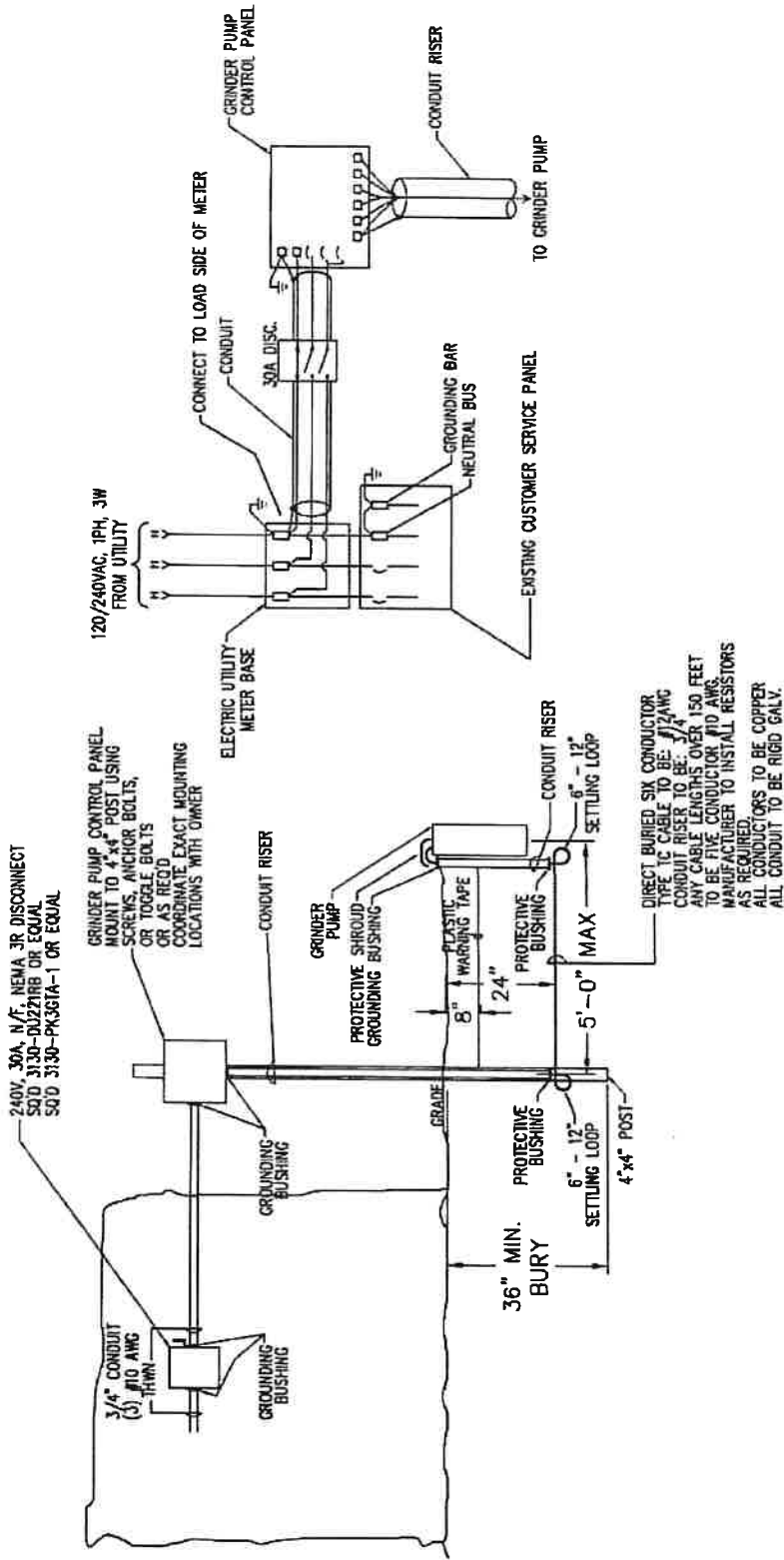

TYPICAL ELEVATION LAYOUT
Not to Scale

TYPICAL SCHEMATIC
Not to Scale

- NOTE:
1. INSTALLATION SHALL COMPLY WITH THE NATIONAL ELECTRICAL CODE.
 2. CALL THE OHIO UTILITIES PROTECTION SERVICE BEFORE DIGGING.
(NON-MEMBERS MUST BE CALLED DIRECTLY)

GRINDER PUMP ELECTRICAL DETAILS



**POGEMEYER
DESIGN GROUP**

A KLEINFELDER COMPANY
101 CLINTON ST., SUITE 1300
DEFIANCE, OH 43512
PH: (419) 782-3067

SEWER CONNECTION

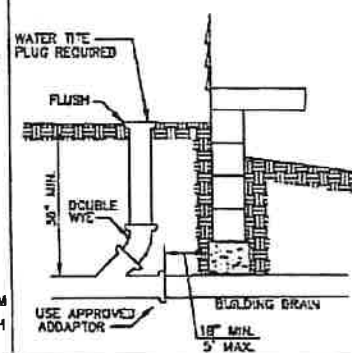
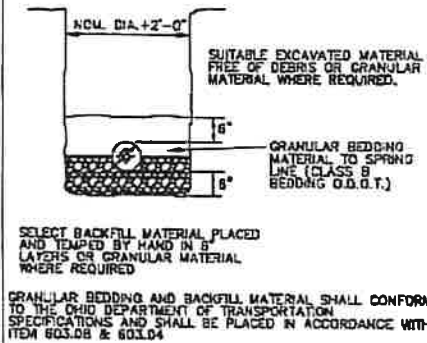
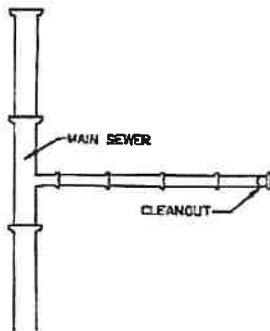
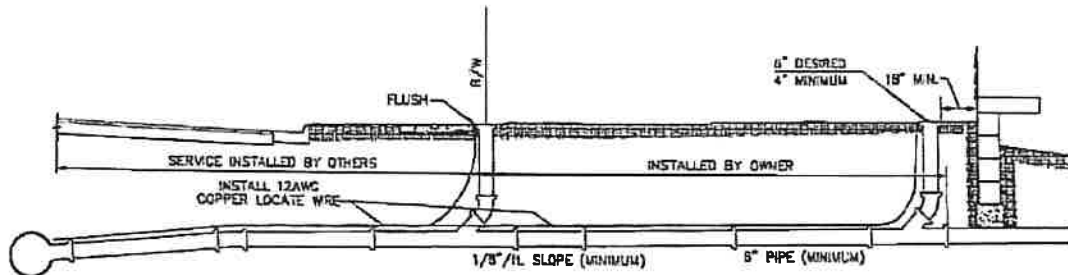

Sanitary Sewer Connection and Tap Standards and Specifications

1. Sewer tap shall be made of the same material as the main sewer to minimize infiltration from the connection between the main sewer and building lateral. All pipes shall be PVC (SDR-35) and conform to ASTM 3034. When joint dimensions are not compatible, a commercial adapter shall be provided.
2. The sewer connection pipe shall be a minimum of 6-inch in diameter.
3. Roof drains, foundation drains and all other clean water connections to the sanitary sewer are prohibited.
4. There shall be no physical connection between a public or private potable water system and a sewer, or appurtenance thereto, which would permit the passage of any sewage or polluted water into the potable supply.
5. Sanitary sewer shall be a minimum of 50 feet from any water supply source (i.e. wells).
6. Sewer cleanout with a removable waterproof cap at the top of the cleanout shall be required and placed about 5 feet from the edge of the building and @ 100' intervals. Refer to the attached details for construction standards. Whenever a cleanout is installed in a driveway, road or sidewalk, a heavy-duty removable waterproof gray iron casting solid lid shall be placed at the top of the cleanout. This lid shall be Neenan Foundry Company R-1976 or approved equal.
7. Sewer pipe shall be laid on and covered with at least 6-inch of granular material (i.e. 8's or 57's stone). Slag is not permitted. There shall be a minimum of 36-inch cover over pipe. Trench backfill shall be of a suitable material removed from the excavation. Debris, frozen material, large clods or stones, organic matter, or other unstable materials shall not be used for backfill within 2 feet of the top of the pipe. Backfill shall be placed in such a manner as not to disturb the alignment of the pipe.
8. Straight lines, proper fittings and provisions for cleaning shall be used to insure proper flow and trouble-free use. Where bends greater than 45° are used, cleanouts shall be installed. Where bends of 45° or less are used, a minimum of one 3-foot straight section of pipe shall separate the bends.
9. The Owner is responsible for notifying all underground utilities of excavating when digging in the service line. All utilities may be notified by calling the Ohio Utilities Protection Service (OUPS) at 1-800-382-2764.
10. Contact the County Health Department for procedures to abandon existing septic tank.



**POGGEMEYER
DESIGN GROUP**

A KLEINFELDER COMPANY

101 CLINTON ST., SUITE 1300
DEFIANCE, OH 43512
PH: (419) 782-3067

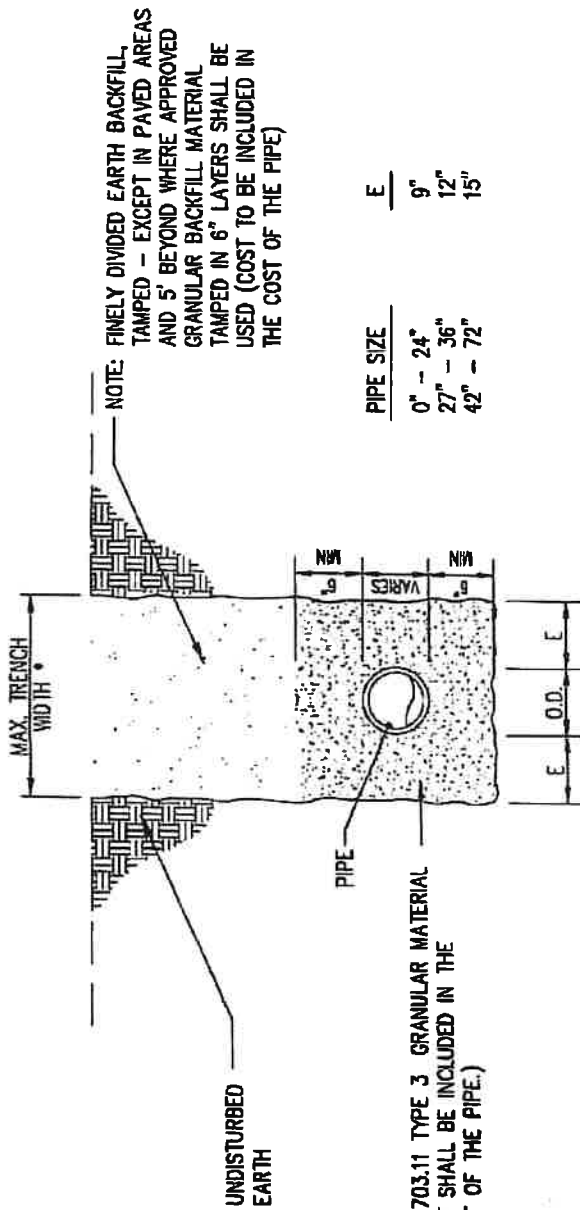

| PIPE SIZE | E |
|-----------|-----|
| 0" - 24" | 9" |
| 27" - 36" | 12" |
| 42" - 72" | 15" |

ODOT 703.11 TYPE 3 GRANULAR MATERIAL (COST SHALL BE INCLUDED IN THE COST OF THE PIPE.)

TRENCH DETAIL

Not to Scale



**POGGEMEYER
DESIGN GROUP**

A KLEINFELDER COMPANY
101 CLINTON ST., SUITE 1300
DEFIANCE, OH 43512
PH: (419) 782-3067

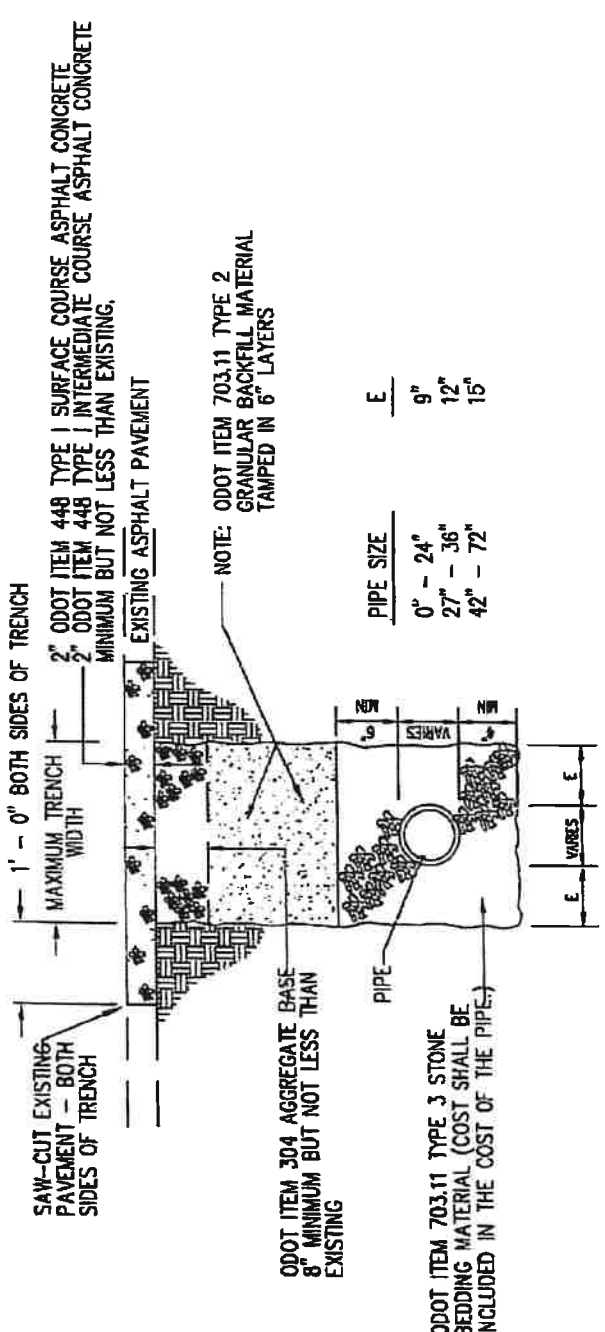

NOTE: ODOT ITEM 703.11 TYPE 2 GRANULAR BACKFILL MATERIAL TAMPED IN 6" LAYERS

| PIPE SIZE | E |
|-----------|-----|
| 0" - 24" | 9" |
| 27" - 36" | 12" |
| 42" - 72" | 15" |

TRENCH DETAIL IN ASPHALT PAVEMENT

TYPE I
NOT TO SCALE



**POGEMEYER
DESIGN GROUP**
A KLEINFELDER COMPANY
101 CLINTON ST., SUITE 1300
DEFIANCE, OH 43512
PH: (419) 782-3067

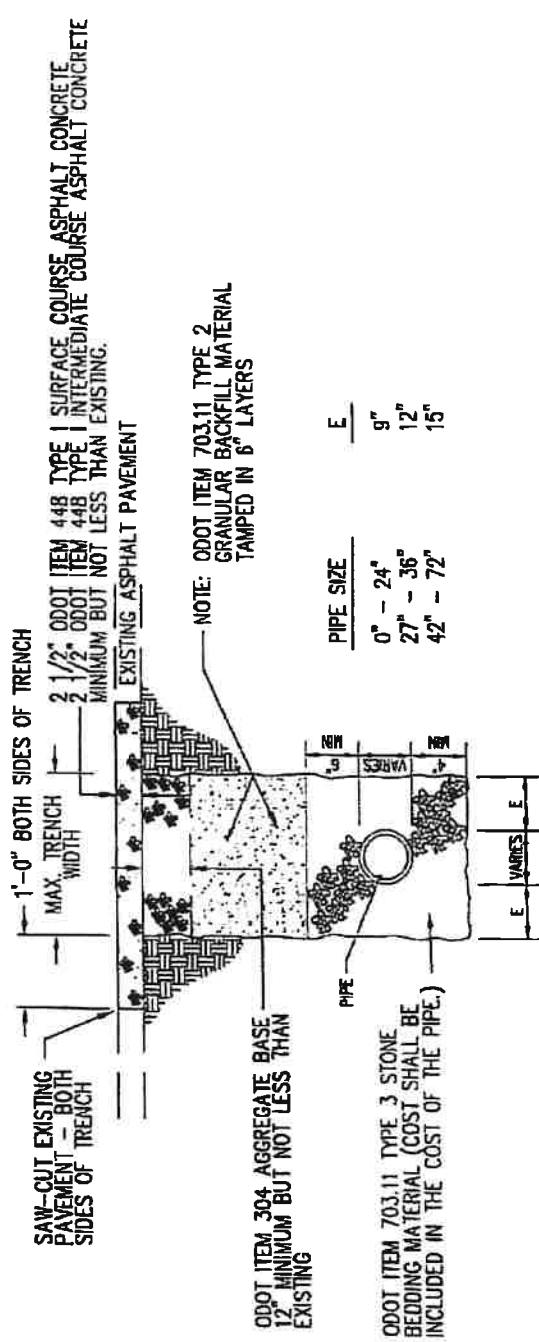

TRENCH DETAIL IN ASPHALT PAVEMENT

TYPE II

Not to Scale



**POGEMEYER
DESIGN GROUP**

A KLEINFELDER COMPANY
101 CLINTON ST., SUITE 1300
DEFANCE, OH 43512
PH: (419) 782-3067

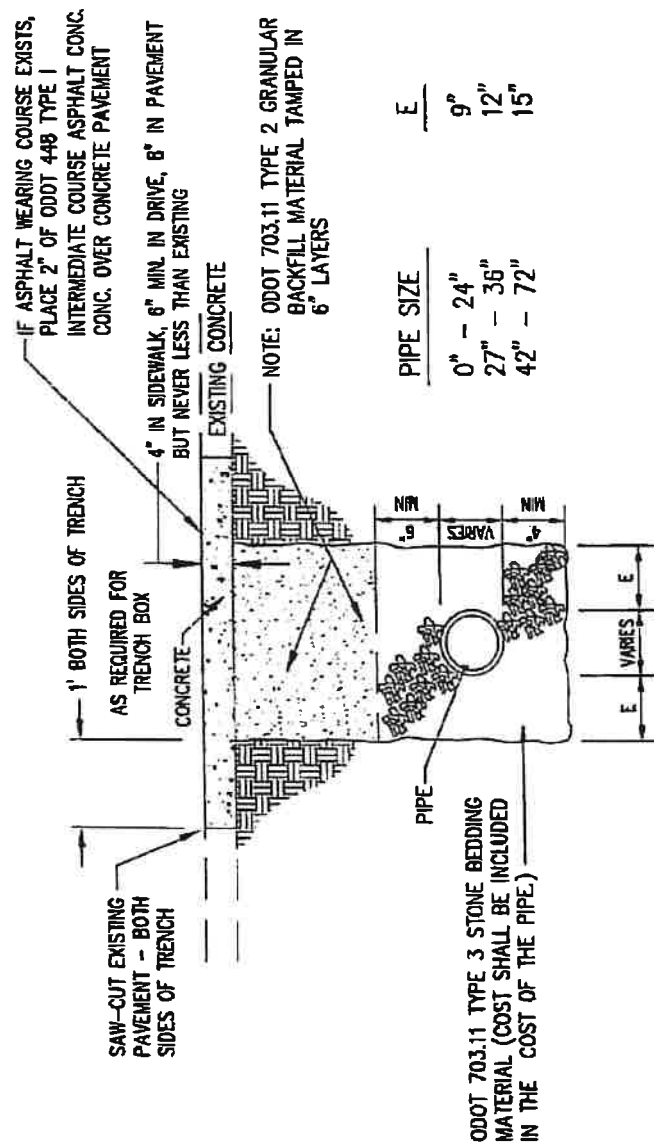

| PIPE SIZE | E |
|-----------|-----|
| 0" - 24" | 9" |
| 27" - 36" | 12" |
| 42" - 72" | 15" |

TRENCH DETAIL IN CONCRETE PAVEMENT/SIDEWALK

Not to Scale



**POGEMEYER
DESIGN GROUP**
A KLEINFELDER COMPANY
101 CLINTON ST., SUITE 1300
DEFIANCE, OH 43512
PH: (419) 782-3067

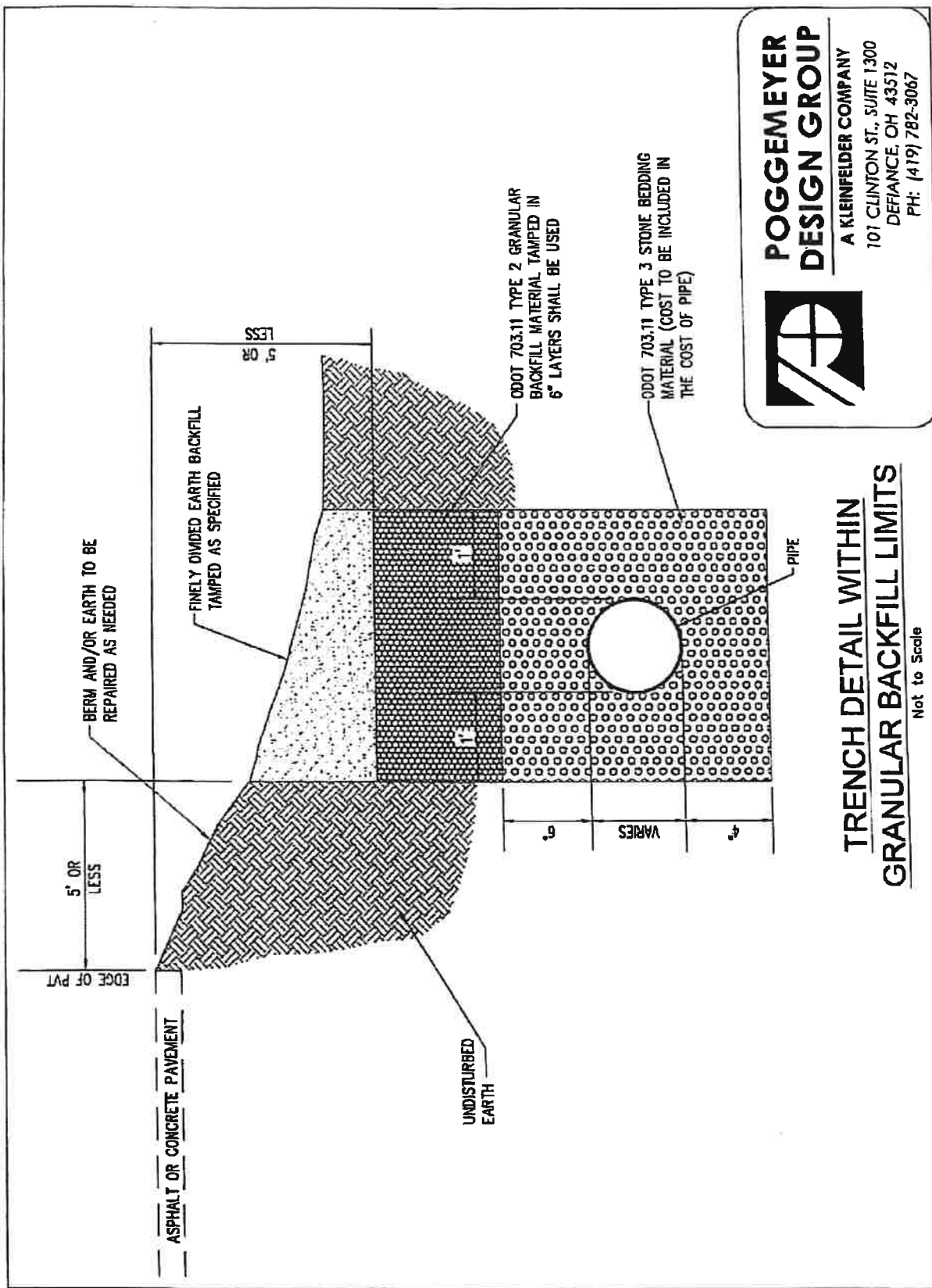

**POGEMEYER
DESIGN GROUP**

A KLEINFELDER COMPANY
 101 CLINTON ST., SUITE 1300
 DEFIANCE, OH 43512
 PH: (419) 782-3067



**TRENCH DETAIL WITHIN
GRANULAR BACKFILL LIMITS**

Not to Scale

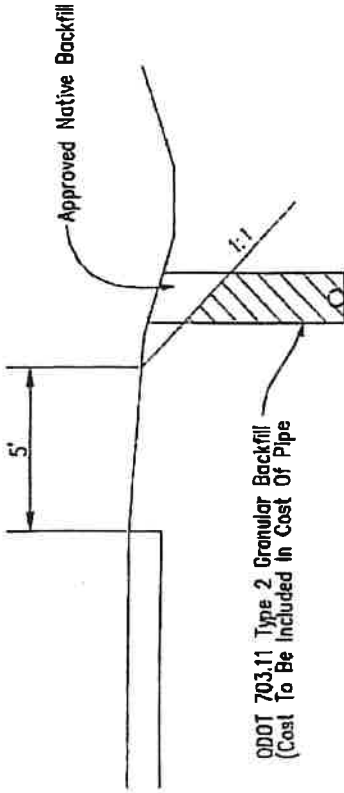

- NOTE :**
1. ALL BACKFILL AND BEDDING MATERIAL SHALL BE PLACED IN MAX. 6" LAYERS AND COMPACTED BEFORE NEXT LAYER IS PLACED.
 2. BEYOND THE HATCH LIMITS SHOWN ON THESE DETAILS, NATIVE BACKFILL APPROVED BY THE ENGINEER MAY BE USED.

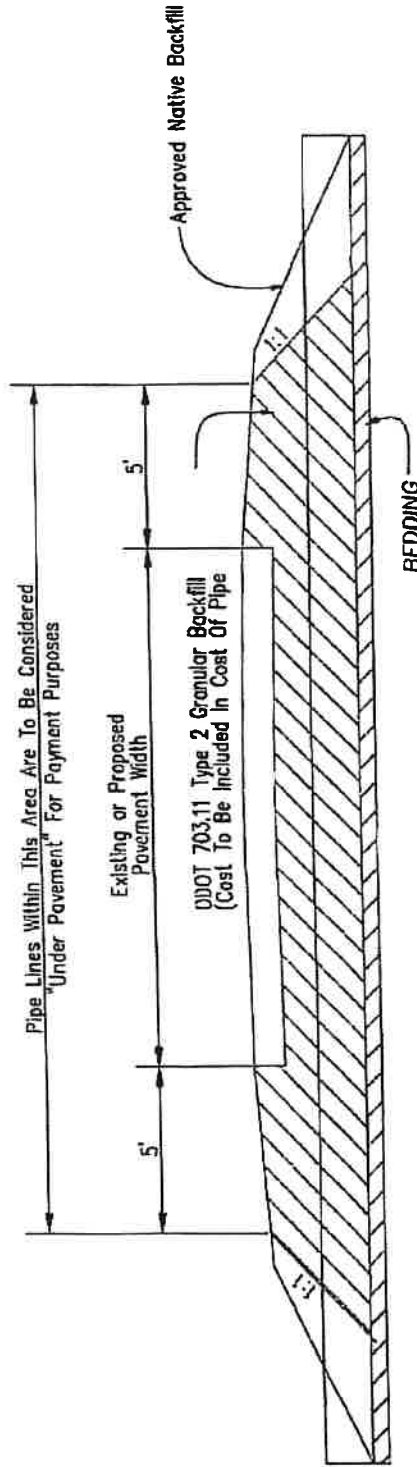

GRANULAR BACKFILL LIMITS DETAILS

Not to Scale



**POGEMEYER
DESIGN GROUP**

A KLEINFELDER COMPANY

101 CLINTON ST., SUITE 1300
DEFIANCE, OH 43512
PH: (419) 782-3067

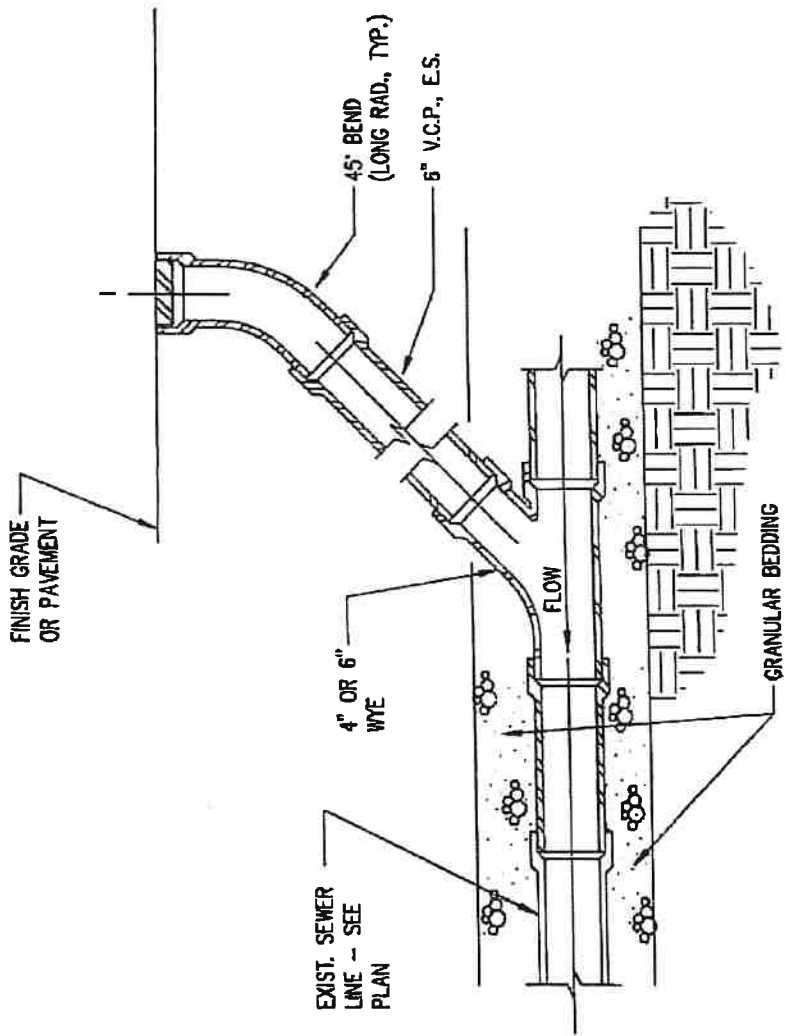

CLEAN-OUT DETAIL

Not to Scale



**POGEMEYER
DESIGN GROUP**

A KLEINFELDER COMPANY
101 CLINTON ST., SUITE 1300
DEFIANCE, OH 43512
PH: (419) 782-3067

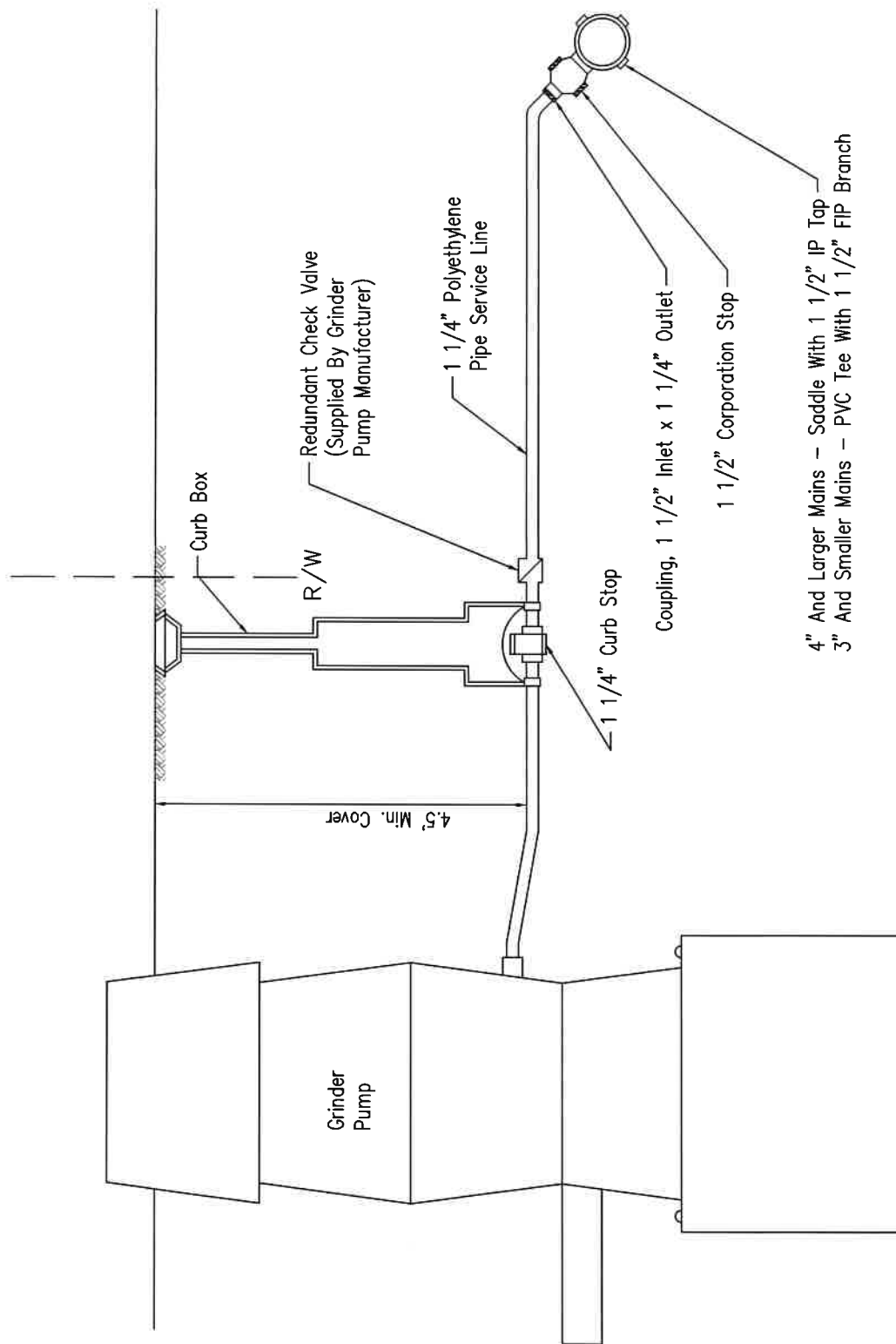

Redundant Check Valve
(Supplied By Grinder
Pump Manufacturer)

1 1/4" Polyethylene
Pipe Service Line

Coupling, 1 1/2" Inlet x 1 1/4" Outlet

1 1/2" Corporation Stop

4" And Larger Mains - Saddle With 1 1/2" IP Tap
3" And Smaller Mains - PVC Tee With 1 1/2" FIP Branch

4.5' Min. Cover

Grinder
Pump

Curb Box

R/W

1 1/4" Curb Stop

GRINDER PUMP CONNECTION DETAIL

Not to Scale



**POGEMEYER
DESIGN GROUP**

A KLEINFELDER COMPANY
101 CLINTON ST., SUITE 1300
DEFIANCE, OH 43512
PH: (419) 782-3067

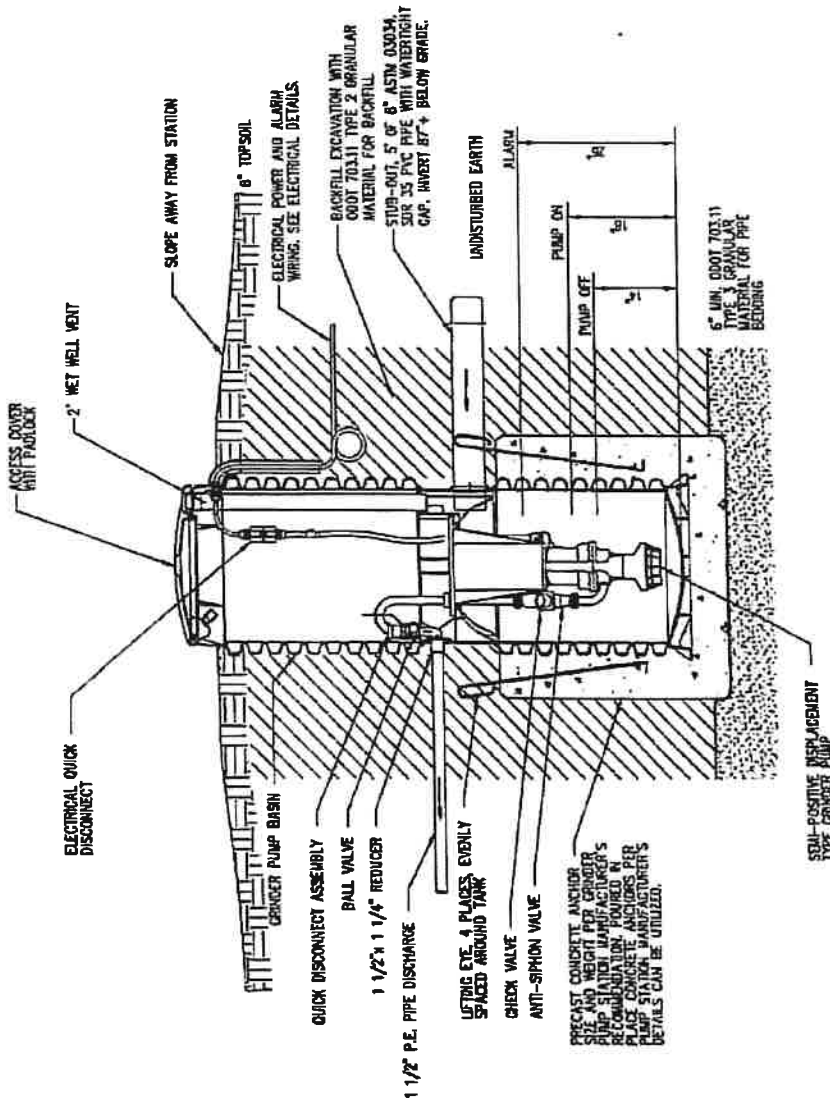

TYPICAL GRINDER PUMP INSTALLATION

Not to Scale

POGEMEYER DESIGN GROUP

A KLEINFELDER COMPANY

101 CLINTON ST., SUITE 1300

DEFIANCE, OH 43512

PH: (419) 782-3067

